

TÉVERE

FORTE EM AÇO

CATÁLOGO DE PRODUTOS

A EMPRESA

Fundada há mais de trinta e seis anos, a Tévere é especializada no mercado do aço e procura aprimorar seus produtos e processos continuamente em busca das melhores soluções para os clientes.

Nosso compromisso é com a satisfação dos clientes e a eficiência de nossos produtos.

Além da preocupação com o relacionamento com os clientes, nós oferecemos produtos de altíssima qualidade, com matéria prima de procedência certificada e sob medida para você.

TÉVERE
FORTE EM AÇO

Índice - Perfis

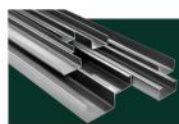

Perfis **11**

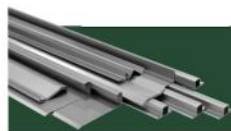

Janelas **21**

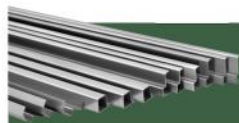

Marco para porta **33**

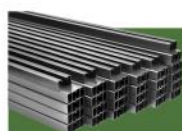

Trilhos **35**

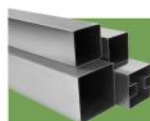

Conjuntos de elevação **39**

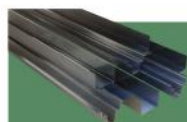

Formas e perfis diversos **57**

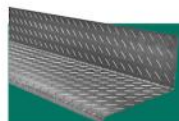

Degraus e calhas de posto **61**



Chapas **65**



Perfis I e W **73**

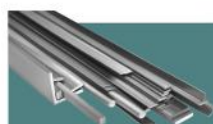

Laminados **77**

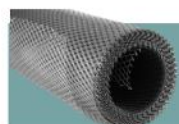

Telas e chapa expandida **81**



Tubos industriais **83**

Índice - Auxiliar

Produto	Pág
T1	25
T2	25
T3	19
T4	25
T5	25
T6	18
T7	18
T8	12
T9	13
T10	26
T12	26
T13	32
T14	15
T15	15
T16	15
T17	15
T18	15
T20	25
T21	15
T22	18
T23	20
T24	20
T25	20
T26	19
T27	18
T28	27
T29	28
T30	32
T31	29
T32	28
T33	28
T34	27
T35	27
T37	28
T38	30
T39	31
T40	27
T41	27

Produto	Pág
T42	27
T43	28
T44	32
T45	29
T46	31
T47	31
T48	22
T49	22
T51	24
T52	24
T53	24
T54	25
T56	34
T57	23
T58	31
T60	26
T66	34
T67	29
T71	26
T73	22
T75	22
T76	19
T79	16
T80	16
T81	16
T82	16
T83	17
T85	36
T86	36
T87	36
T89	34
T91	55
T92	42
T92A	42
T94	44
T94A	44
T95	46
T95A	47

Produto	Pág
T96	66
T97	68
T98	46
T99	47
T100	49
T112	58
T113	69
T115	41
T116	45
T117	48
T118	51
T119	53
T120	40
T120A	40
T121	41
T121A	40
T122	43
T122A	42
T123	45
T123A	44
T124	47
T125	51
T125A	50
T126	53
T126A	52
T127	43
T128	45
T129	48
T130	51
T131	53
T132	52
T132A	52
T133	50
T133A	50
T134	52
T136	53
T137	55
T138	56
T139	56

Produto	Pág
T142	59
T148	37
T149	37
T150	37
T152	17
T156	23
T157	23
T158	59
T179	17
T180	67
T181	41
T182	43
T183	30
T184	30
T185	38
T186	23
T187	59
T188	58
T193	56
T194	67
Calhas	64
Acessórios	90
Calandras	60
Chapas Expandidas	82
Chapas lisas	70
Chapas lisas Inox	72
Chapas Xadrez	71
Degraus	62
Laminados	78
Negativas	54
Plasma	60
Tampas rebaixadas	54
Telas	82
Telhas	108
Tubos industriais	84
Vigas I e W	74

Índice - Acessórios

Eletrodos	90	Tampas de tubo	97
Arame MIG	90	Consoles	97
Arruelas	90	Clips cabo de aço	97
Alavancas	90	Cabo de aço	98
Suporte	90	Guias	98
Bate fecha	91	Haste	100
Fecho portão	91	Pino pantográfico	100
Puxadores	91	Veda calha e PU	100
Rebite	92	Pontas de lança	100
Rodízios	92	Barra rosqueada	101
Buchas	93	Discos	102
Roldanas	94	Chapéu para coluna	102
Dobradiças	96	Parafusos	103
Curva 90°	96	Fechaduras Stam	104
Ferrolho fio redondo	96	Maçanetas	106

Índice - Telhas

Telha TP-40 **107**

Telha ondulada **107**

Telha TP-25 **107**

Telhas isotérmicas **111**

Telhas translúcidas **115**

Cumeeira e multidobra **117**

Abreviações

Cromado CR

Aço inoxidável Zinco INOX

branco ZB

Zinco amarelo ZA

Zincado ZN

Zincado cromado ZCR

Polido PO

Latonado oxidado LO

Galvanizado GV

Escariado ESCAR

Ferro polido FP

Grafite GRAFITE

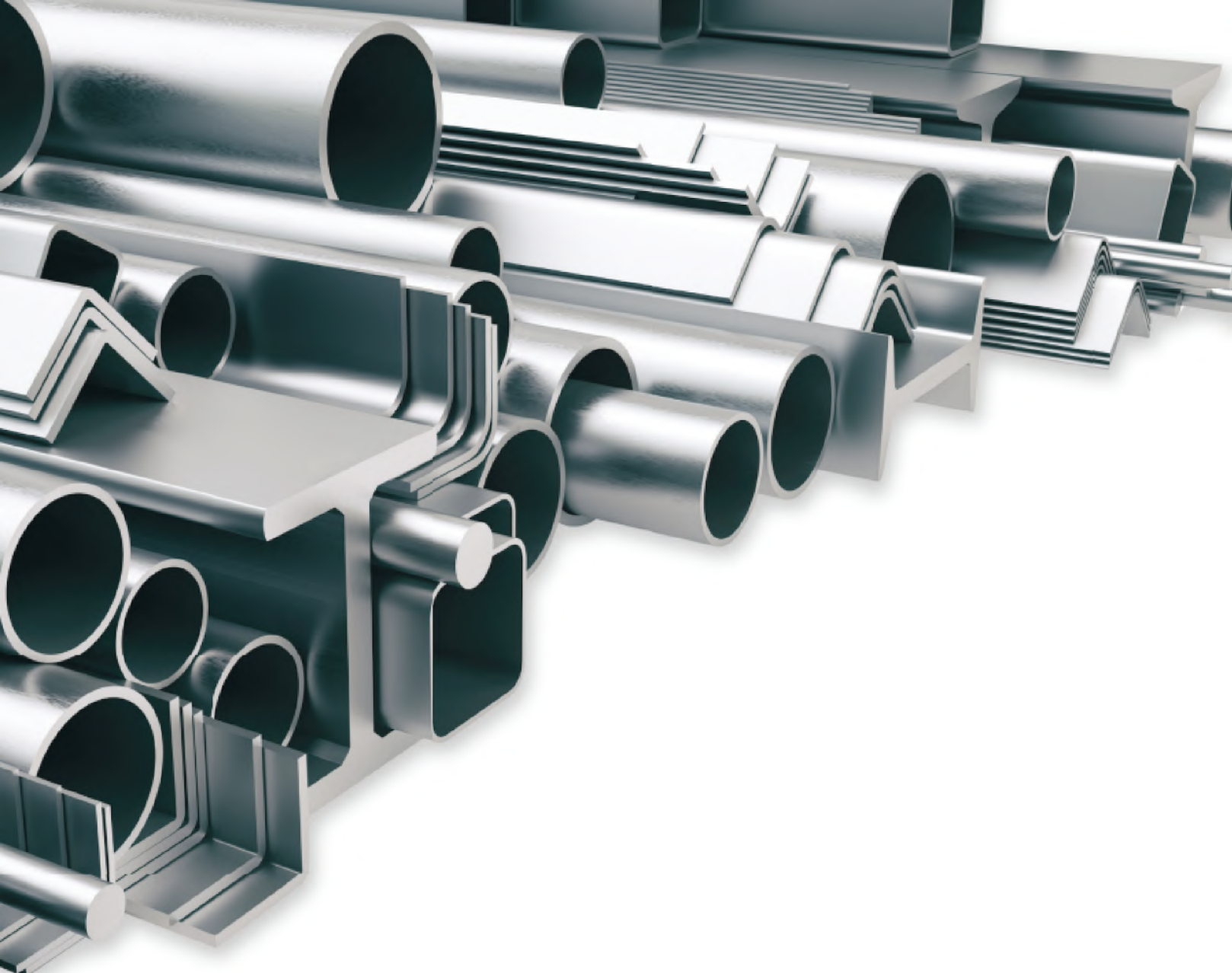

TÉVERE

FORTE EM AÇO

PRODUTOS

Todos os produtos Tévere são produzidos com matéria prima de procedência certificada, sob os mais rígidos padrões de qualidade e com ampla variedade de espessuras e tamanhos, podendo até mesmo ser feito sob medida para atender melhor suas necessidades.

Neste catálogo você encontrará as famílias Perfis, Janelas, Marco para Porta, Trilhos, Conjuntos de Elevação, Formas, Perfis Diversos, Degraus, Calha de Posto, Chapas e Tubos.

Perfis

- Perfil estrutural perfiladeira
- Perfil estrutural dobradeira
- Perfil "L" cantoneira dobrada
- Perfil "U" serralheiro
- Perfil para porta de rolo
- Perfil para pantográfica

FAMÍLIA PERFIS

Os perfis de aço Tévere são produzidos de acordo com as normas nacionais e dentro dos mais rigorosos padrões de qualidade.

Fornecemos produtos em tamanho padrão ou de acordo com a necessidade do cliente. Também possuímos uma ampla variedade de espessuras e medidas, como chapas Fina Frio, Fina Quente, Galvanizada, Cosa Cor, A36, Civil 300, que possibilitam melhores soluções de encaixes e acabamentos no seu produto final.

Devido à alta qualidade de nosso acabamento, os perfis Tévere podem ser usados em aplicações aparentes para composição de estruturas metálicas, fachadas e coberturas.

Perfil Estrutural Perfiladeira

T8 - Terças Enrijecidas com 6m

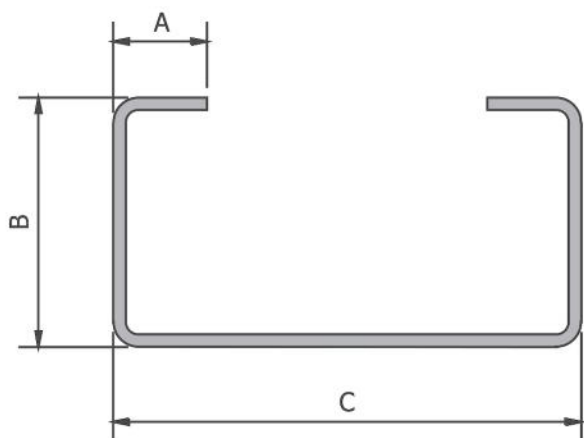

A	B	C	CH	kg/m
10	25	50	2,00	1,66
10	25	50	2,25	1,84
10	25	50	2,65	2,09
10	25	50	3,00	2,30

16	40	75	2,00	2,74
16	40	75	2,25	3,04
16	40	75	2,65	3,51
16	40	75	3,00	3,91

15	40	100	2,00	3,10
15	40	100	2,25	3,46
15	40	100	2,65	4,00
16	40	100	3,00	4,51

17	50	100	2,00	3,49
17	50	100	2,25	3,89
17	50	100	2,65	4,51
17	50	100	3,00	5,04

17	50	126	2,00	3,90
17	50	126	2,25	4,36
17	50	126	2,65	5,06
17	50	126	3,00	5,66

A	B	C	CH	kg/m
20	60	150	2,00	4,70
20	60	150	2,25	5,26
20	60	150	2,65	6,12
20	60	150	3,00	6,86

25	75	200	2,00	6,06
25	75	200	2,25	6,88
25	75	200	2,65	8,03
25	75	200	3,00	9,02



DICA

Além dos materiais produzidos com medidas padrão, produzimos peças com comprimentos/medidas especiais. Consulte-nos!

Perfil Estrutural Perfiladeira

T9 - Perfil U com 6m

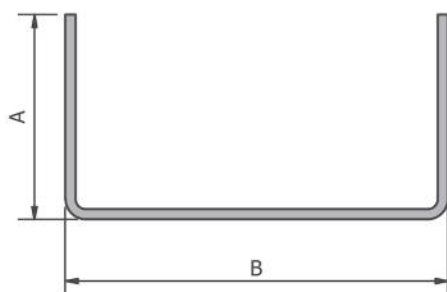

A	B	CH	kg/m
U DE FORA 2,0			
25	50	0	1,47
25	50	2,25	1,64
25	50	2,65	1,90
25	50	3,00	2,11
U DE FORA			
40	75	2,00	2,35
40	75	2,25	2,63
40	75	2,65	3,06
40	75	3,00	3,43
USAR OS ENCAIXES PARA "U" 40 x 75			
30	68	2,00	1,92
30	68	2,25	2,14
30	68	2,65	2,49
30	68	3,00	2,78
USAR OS ENCAIXES PARA "U" 30 x 68 CH-2,00MM E 2,25MM PERFIS DOBRADEIRA			
22	63	2,00	1,58
27	63	2,00	1,74
U DE FORA			
40	100	2,00	2,75
40	100	2,25	3,08
40	100	2,65	3,59
40	100	3,00	4,03
50	100	2,00	3,07
50	100	2,25	3,44
50	100	2,65	4,02
50	100	3,00	4,51
USAR OS ENCAIXES PARA "U" 40 x 100 e 50 X 100			
32	94	2,00	2,40
32	94	2,65	2,68
32	94	3,00	3,12
32	94	2,65	3,50

A	B	CH	kg/m
12 U DE FORA 2,0			
50	6	0	3,49
50	126	2,25	3,91
50	126	2,65	4,57
50	126	3,00	5,14
USAR OS ENCAIXES PARA "U" 50 x 126			
40	75	2,00	2,35
40	75	2,25	2,63
40	75	2,65	3,06
40	75	3,00	3,43
U DE FORA			
50	150	2,00	3,87
50	150	2,25	4,34
50	150	2,65	5,08
50	150	3,00	5,71
USAR OS ENCAIXES PARA "U" 50 x 126			
40	143	2,00	3,44
40	143	2,25	3,85
40	143	2,65	4,50
40	143	3,00	5,06
U DE FORA			
50	200	2,00	4,67
50	200	2,25	5,24
50	200	2,65	6,14
50	200	3,00	6,91
ENCAIXE SOB CONSULTA DE MEDIDAS - CONSULTE-NOS			



DICA

Os perfis U Tévere permitem diferentes combinações para atender à requisitos do seu projeto. Consulte-nos!

Perfil Estrutural Dobradeira

T9 - Perfil U com 6m

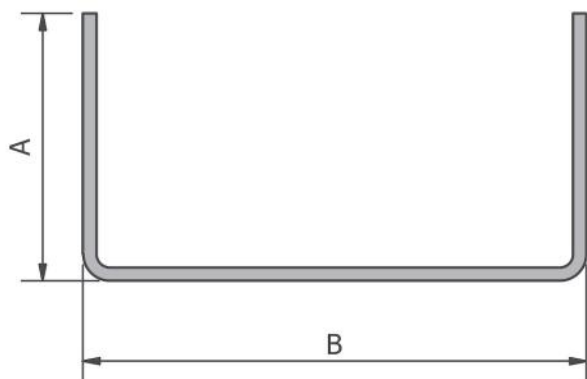

A	B	CH	kg/m
ENCAIXES DO U 25 X 50			
* 21	45	0	1,26
* 21	45	2,25	1,40
ENCAIXES DO U 30 X 68			
** 22	63	2,00	1,58
** 27	63	2,00	1,74
40	76	4,75	5,21
40	76	6,30	6,59
40	100	4,75	6,12
40	100	6,30	7,80
50	100	4,75	6,88
50	100	6,30	8,81

A	B	CH	kg/m
U DE FORA			
*** 50	126	3,35	5,70
*** 51	128	4,25	7,24
*** 51	129	4,75	8,06
U DE FORA			
**** 51	151	3,35	6,42
**** 51	152	3,75	7,17
**** 51	153	4,25	8,09
**** 52	154	4,75	9,08
50	120	4,75	7,64
52	120	6,30	10,02

Atenção: os asteriscos denominam a regra abaixo:

*Encaixe do U 25x50

**Encaixe do U 30x68

***Usar os encaixes de perfiladeira 45x118

****Usar os encaixes de perfiladeira 40x143



DICA

Os perfis de encaixe dobradeira possuem a qualidade para atender todas as suas necessidades. Produzimos perfis terças em dobradeira sob medida. Consulte-nos!

Perfil "L" cantoneira dobrada

T14 - Cantoneira dobrada

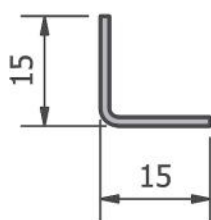

esc. 1:1

CH	COMP.	PESO kg
1,20mm	3000mm	0,80

T15 - Cantoneira dobrada

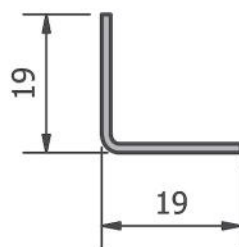

esc. 1:1

CH	COMP.	PESO kg
1,20mm	3000mm	1,02

T16 - Cantoneira dobrada

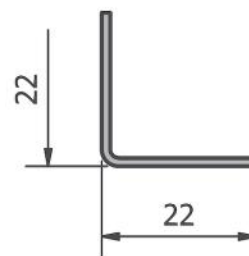

esc. 1:1

CH	COMP.	PESO kg
1,50mm	3000mm	1,50

T17 - Cantoneira dobrada

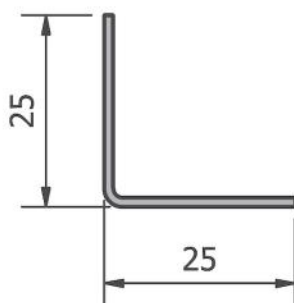

esc. 1:1

CH	COMP.	PESO kg
1,20mm	3000mm	1,40

T18 - Cantoneira dobrada

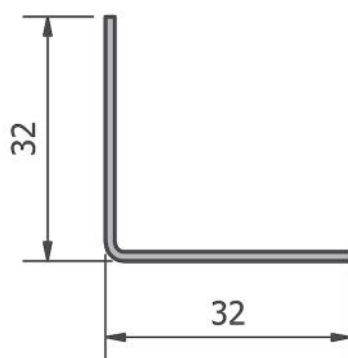

esc. 1:1

CH	COMP.	PESO kg
1,20mm	3000mm	1,76
1,50mm	3000mm	2,16
2,00mm	3000mm	2,84

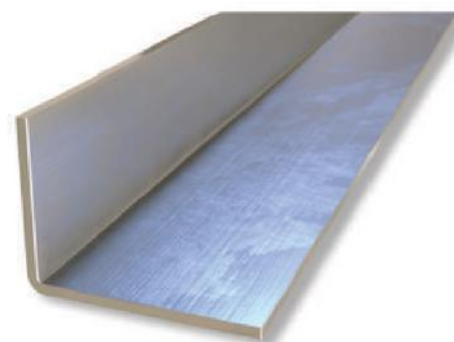

T21 - Cantoneira dobrada

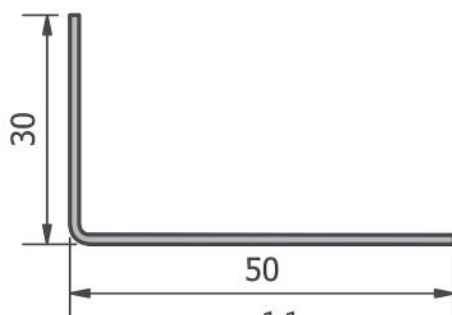

esc. 1:1

CH	COMP.	PESO kg
1,20mm	3000mm	2,28



DICA

As cantoneiras de chapas dobradas podem ser utilizadas em:

- Janelas
- Portas
- Cantos de paredes

Consulte nossos materiais com medidas em outras espessuras.

Perfil "U" serralheiro

T79 - Perfil U serralheiro

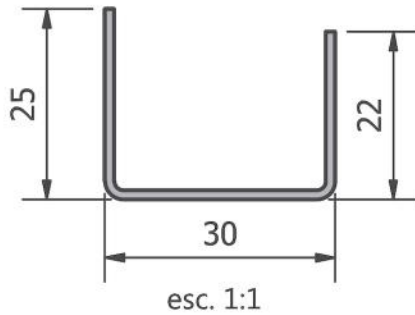

CH	COMP.	PESO kg
1,20mm	3000mm	2,10

T80 - Perfil U serralheiro

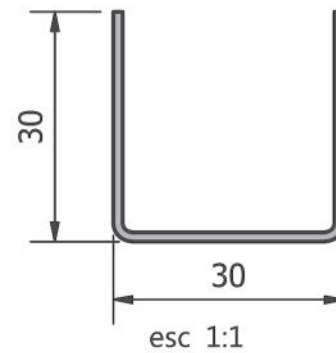

CH	COMP.	PESO kg
1,20mm	3000mm	2,49

T81 - Perfil U serralheiro

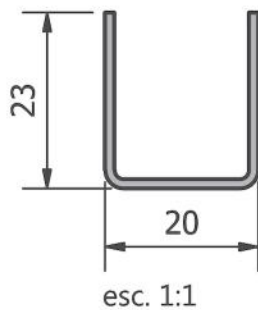

CH	COMP.	PESO kg
1,50mm	3000mm	2,18



T82 - Perfil U serralheiro

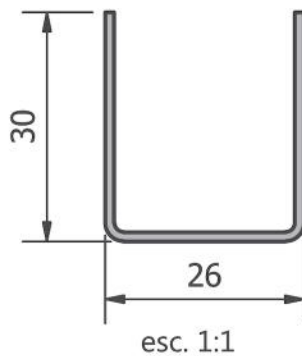

CH	COMP.	PESO kg
1,50mm	3000mm	2,92

DICA

O perfil U serralheiro pode ser utilizado em:

- Grades
- Janelas
- Portas
- Acabamentos diversos

Perfil "U" serralheiro

T83 - Perfil U serralheiro

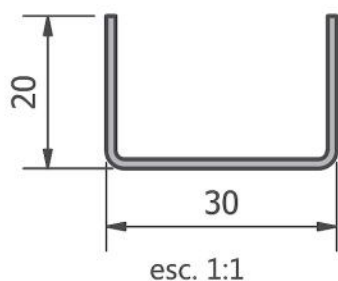

CH	COMP.	PESO kg
1,20mm	3000mm	1,90



T152 - Perfil U serralheiro

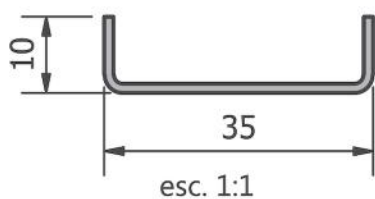

CH	COMP.	PESO kg
1,20mm	3000mm	1,41



DICA

O perfil U serralheiro pode ser utilizado em:

- Grades
- Janelas
- Portas
- Acabamentos diversos

T179 - Perfil U serralheiro

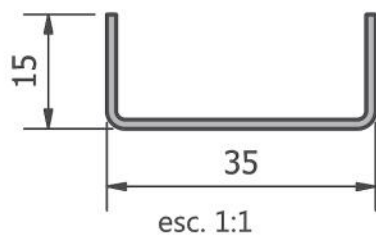

CH	COMP.	PESO kg
1,20mm	2500mm	1,50
1,20mm	3000mm	1,75
1,50mm	3000mm	2,10



Perfil para porta de rolo

T6 - Perfil U

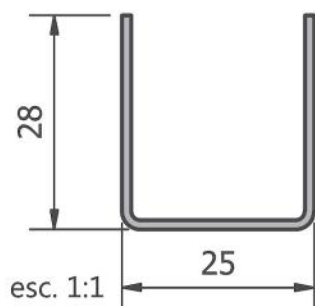

CH	COMP.	PESO kg
1,50mm	3000mm	2,75

T7 - Perfil

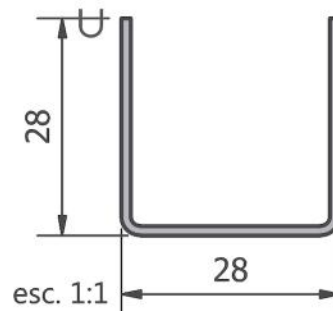

CH	COMP.	PESO kg
1,20mm	3000mm	2,30
1,50mm	3000mm	2,85

T22 - Perfil L

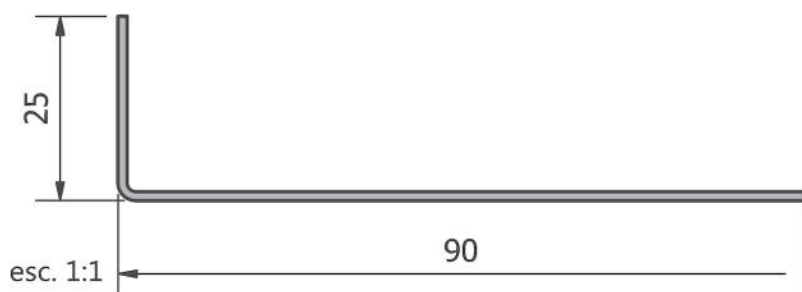

CH	COMP.	PESO kg
1,20mm	3000mm	3,50
1,50mm	3000mm	4,10

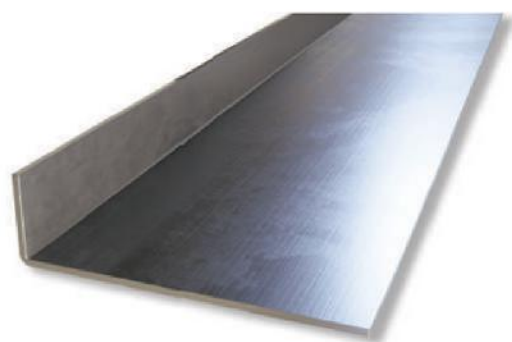

T27 - Perfil H móvel

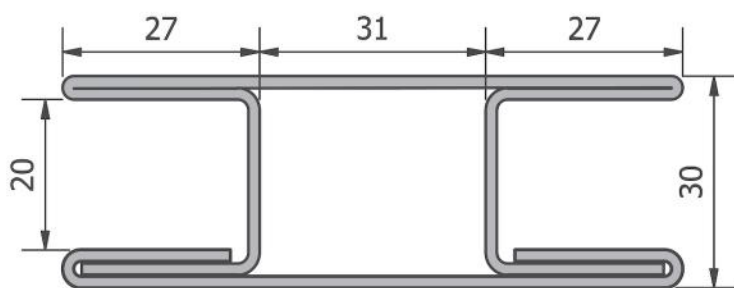

CH	COMP.	PESO kg
1,55mm	3000mm	13,30



DICA

Utilize o perfil H móvel para obter maior espaço em sua obra / porta / abertura.

Perfil para pantográfica

T3 - Perfil U

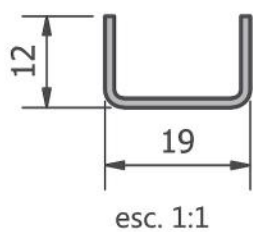

CH	COMP	PESO kg
1,20mm	2300mm	0,85
1,20mm	2500mm	0,92
1,20mm	3000mm	1,10
1,50mm	2300mm	1,00
1,50mm	2500mm	1,09
1,50mm	3000mm	1,30

T76 - Perfil U

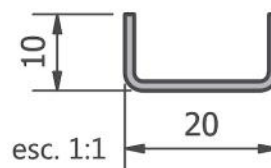

CH	COMP.	PESO kg
1,20mm	2300mm	0,79
1,20mm	3000mm	1,02
1,50mm	2300mm	0,96
1,50mm	2500mm	1,04

T26 - Trilho inferior

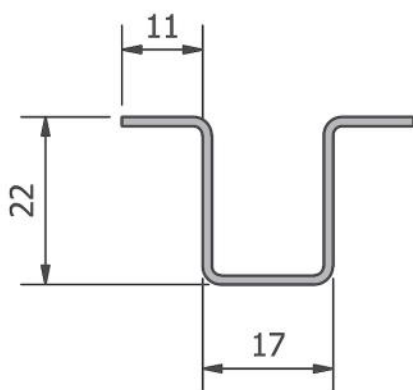

esc. 1:1

CH	COMP.	PESO kg
1,20mm	3000mm	2,19
1,50mm	3000mm	2,67
1,25mm GV	3000mm	2,28
1,55mm GV	3000mm	2,67

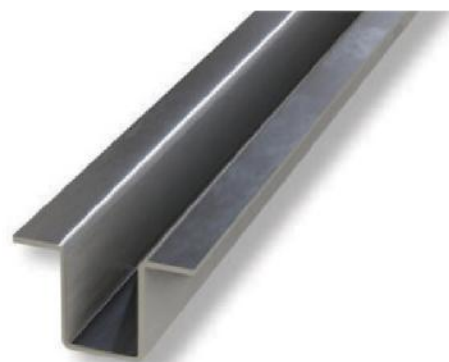

DICA

Utilize os acessórios Tévere para fabricação de pantográfica, como:

- Arruela
- Bucha
- Haste
- Guia T maior
- U sanfona
- Guia T menor
- Puxador U alça

Perfil para pantográfica

T23 - Trilho superior

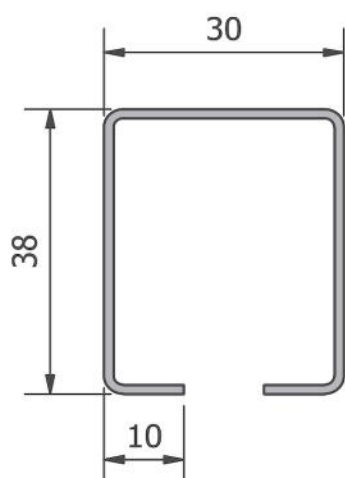

esc. 1:1

CH	COMP.	PESO kg
1,20mm	3000mm	3,40
1,50mm	3000mm	4,17

T24 - Trilho superior

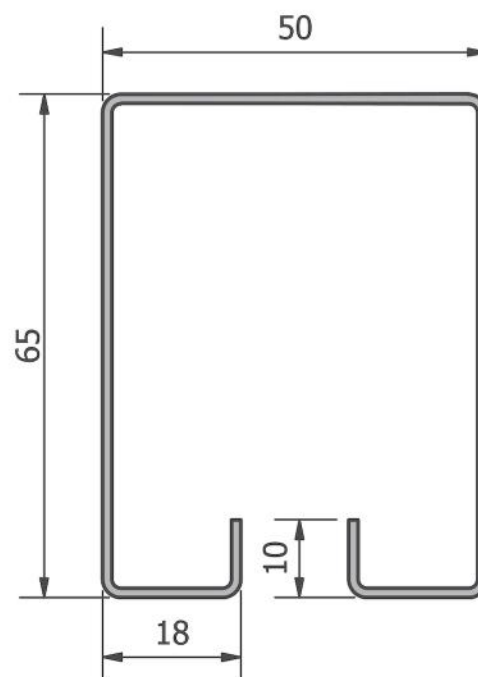

esc. 1:1

CH	COMP.	PESO kg
1,50mm	3000mm	7,98

T25 - Trilho superior

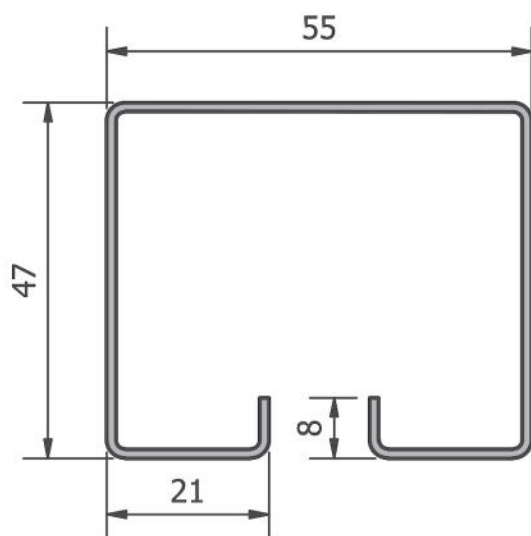

esc. 1:1

CH	COMP.	PESO kg
1,20mm	3000mm	5,65
1,50mm	3000mm	6,99
2,00mm	3000mm	9,10
1,25mm GV	3000mm	5,70
1,55mm GV	3000mm	7,00
2,05mm GV	3000mm	9,37



DICA

Pode ser utilizado com os rodízios duplos. Ver página 92 no catálogo de acessórios.

Janelas

- Soleira para janela
- Palheta para veneziana
- Perfil para janela comum
- Perfil para janela linhas 20, 25, 40, 50 e outros.
- Perfil para janela maximar

FAMÍLIA JANELAS

Os perfis de janela em aço da Tévere são conhecidas no ramo da construção, engenharia, arquitetura e até mesmo pelo consumidor final, pois, são altamente resistentes e seguros.

Entre suas principais aplicações estão: o uso em esquadrias de portas e janelas, bem visíveis, muitas vezes fazendo parte da decoração no seu ambiente.

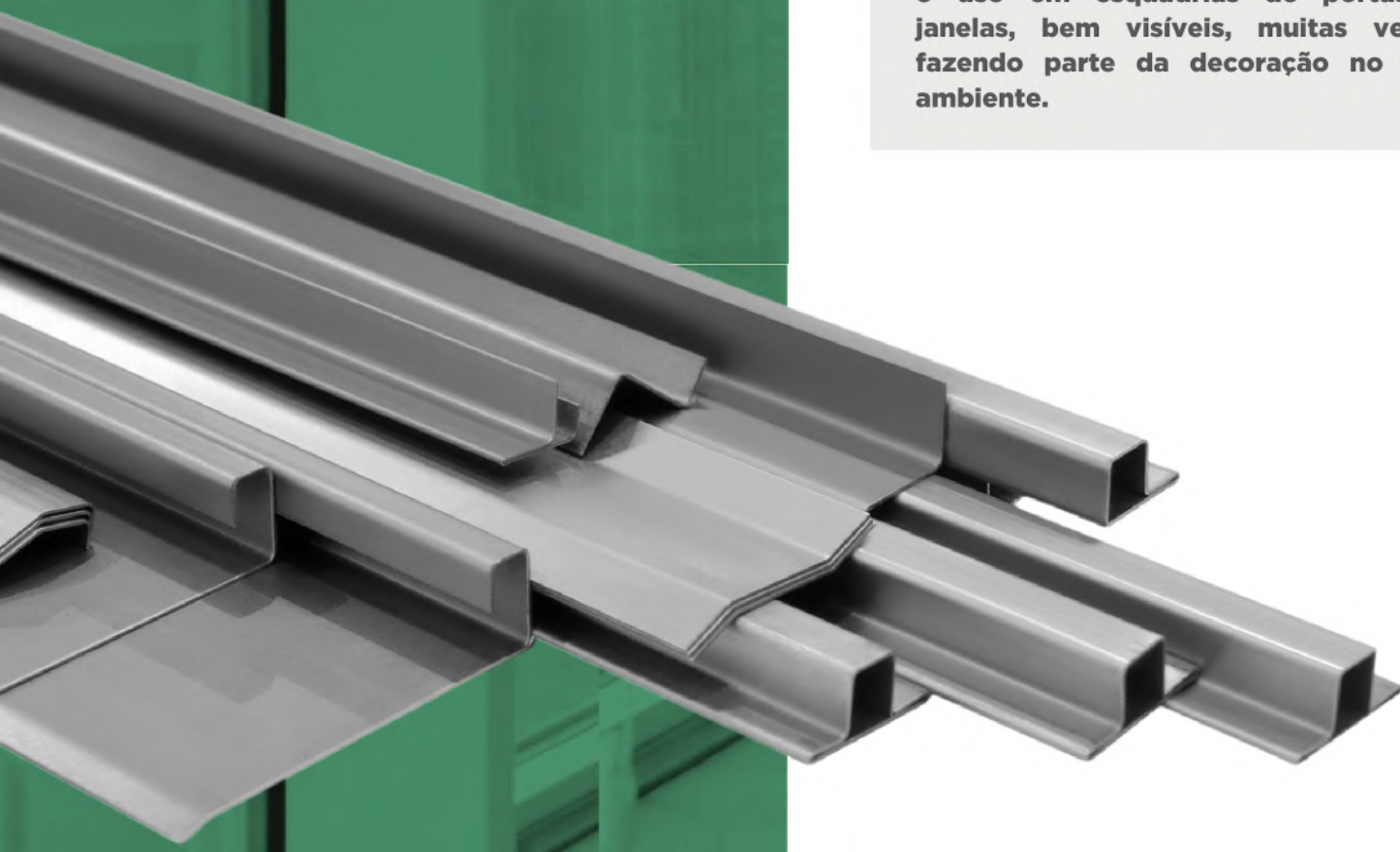

Soleira para janela

T75 - Soleira

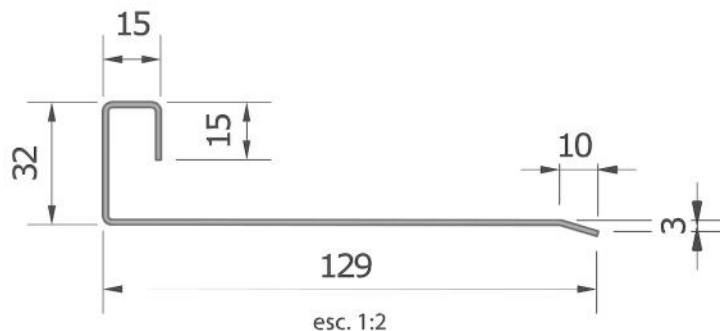

CH	COMP.	PESO kg
1,20mm	3000mm	5,56

T49 - Soleira

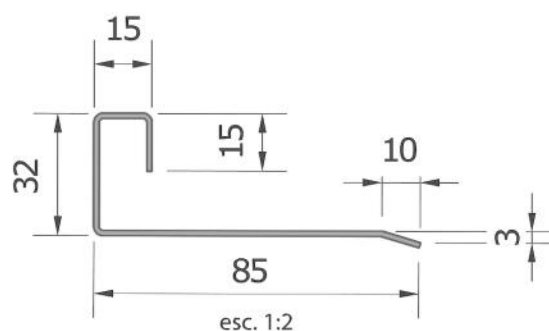

CH	COMP.	PESO kg
1,20mm	3000mm	4,10

T48 - Soleira

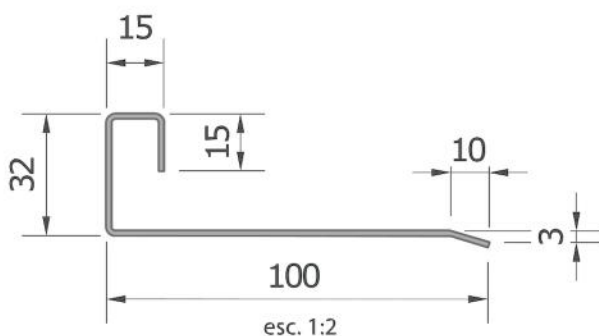

CH	COMP.	PESO kg
1,20mm	3000mm	4,54

DICA

Utilize a soleira para janela em chapa galvanizada, evitando a corrosão precoce do material.



T73 - Soleira

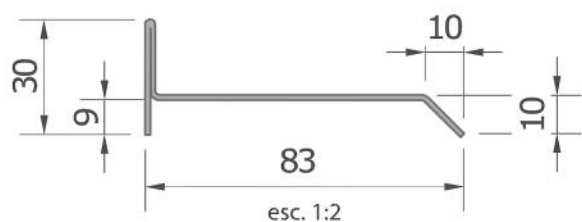

CH	COMP.	PESO kg
1,20mm	3000mm	4,11



Soleira para janela - diversos

T186 - Soleira

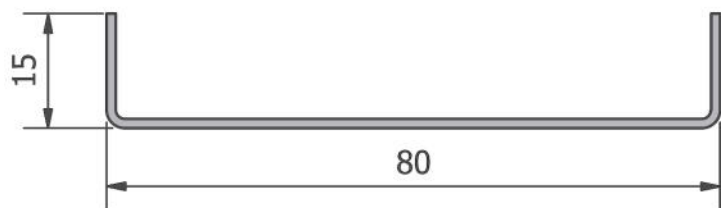

esc. 1:1

CH	COMP.	PESO Kg
1,50mm	3000mm	3,68

T57 - Soleira

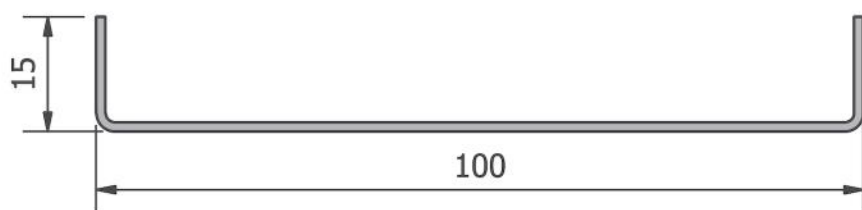

esc. 1:1

CH	COMP.	PESO kg
1,20mm	3000mm	3,60

T156 - Perfil Z simples

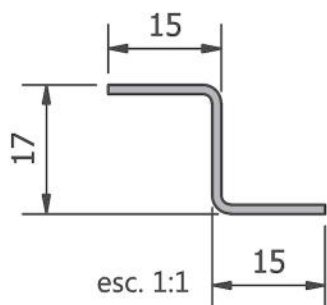

esc. 1:1

CH	COMP.	PESO kg
1,20mm	3000mm	1,19



T157 - Perfil Z simples 19

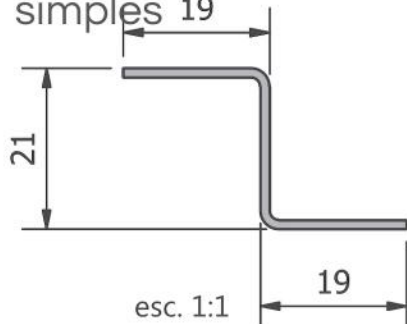

esc. 1:1

CH	COMP.	PESO kg
1,20mm	3000mm	1,52
1,50mm	3000mm	1,90

Palheta para veneziana

T51 - Palheta

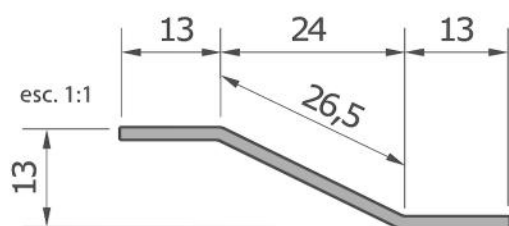

CH	COMP.	PESO kg
1,20mm	3000mm	1,49
1,50mm	3000mm	1,90
1,25mm GV	3000mm	1,90



T52 - Palheta

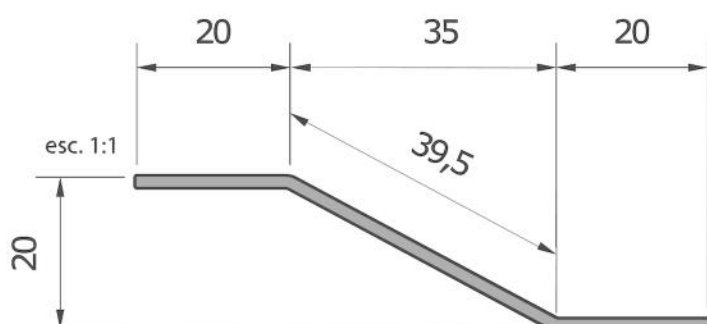

CH	COMP.	PESO kg
1,20mm	3000mm	2,34
1,50mm	3000mm	2,82
1,25mm GV	3000mm	2,43

DICA

Para ter um ótimo acabamento e ambientes com maior ventilação, utilize as palhetas de veneziana.



T53 - Palheta

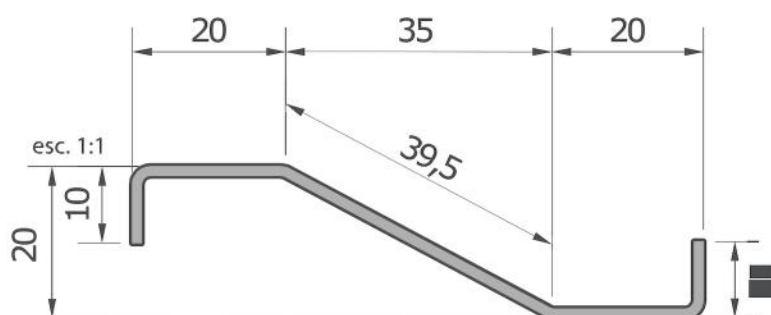

CH	COMP.	PESO kg
1,20mm	3000mm	2,81
1,50mm	3000mm	3,33



Perfil para janela comum

T1 - Baguete de ferro

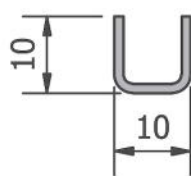

esc 1:1

CH	COMP	PESO kg
1,20mm	3000mm	0,70

T2 - Baguete de ferro

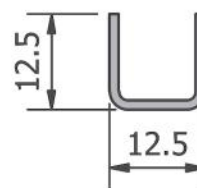

esc 1:1

CH	COMP.	PESO kg
1,20mm	3000mm	0,96

T4 - Perfil U

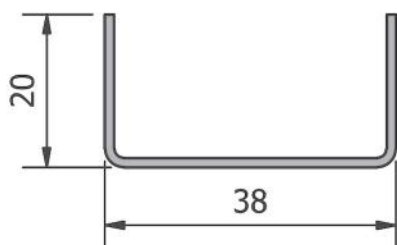

esc. 1:1

CH	COMP.	PESO kg
1,50mm	3000mm	2,60

T54 - Perfil F

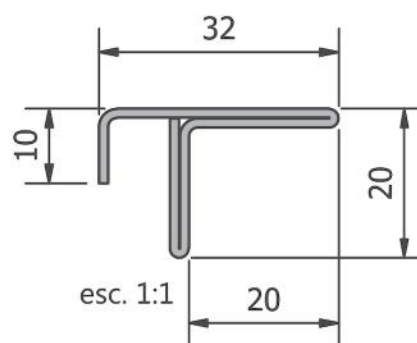

esc. 1:1

CH	COMP.	PESO kg
1,20mm	3000mm	2,78

T5 - Perfil U manco

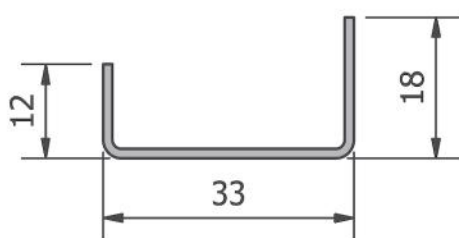

esc. 1:1

CH	COMP.	PESO kg
1,20mm	3000mm	1,70

T20 - Perfil L

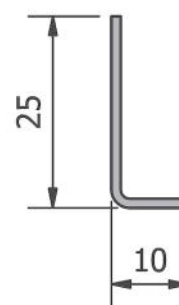

esc. 1:1

CH	COMP.	PESO kg
1,20mm	3000mm	0,96
1,50mm	3000mm	1,17
1,25mm GV	3000mm	1,00

Perfil para janela comum

T71 - Perfil F

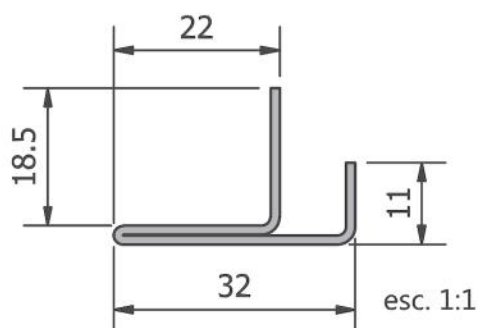

CH	COMP.	PESO kg
1,20mm	3000mm	2,31

T10 - Perfil Z

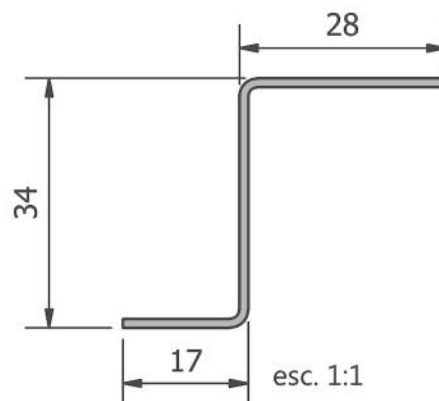

CH	COMP.	PESO kg
1,20mm	3000mm	2,17

T12 - Perfil

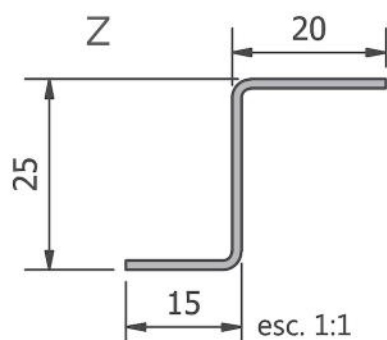

CH	COMP.	PESO kg
1,20mm	3000mm	1,61



T60 - Trilho superior

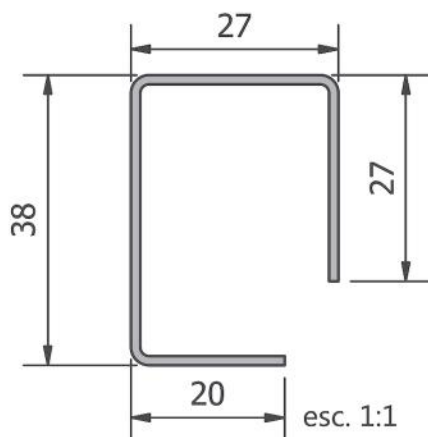

CH	COMP.	PESO kg
1,20mm	3000mm	3,07

DICA

Utilize os perfis para janela em aço para maior segurança e resistência em sua obra.



Perfil para janela linha 20

T28 - Perfil T amassado

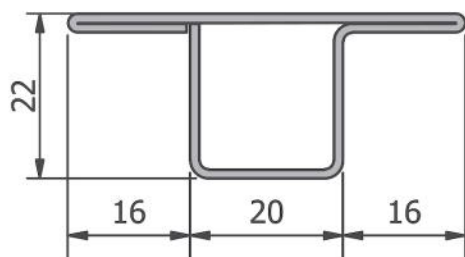

esc. 1:1

CH	COMP.	PESO kg
1,20mm	3000mm	4,10
1,25mm GV	3000mm	4,22

T42 - Perfil cantoneira amassada

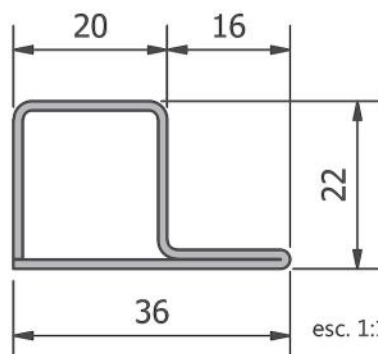

esc. 1:1

CH	COMP.	PESO kg
1,20mm	3000mm	3,10
1,55mm GV	3000mm	3,87

T34 - Perfil F amassado

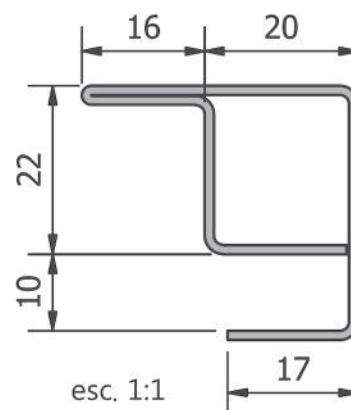

esc. 1:1

CH	COMP.	PESO kg
1,20mm	3000mm	3,86
1,25mm GV	3000mm	4,00

T35 - Perfil F amassado

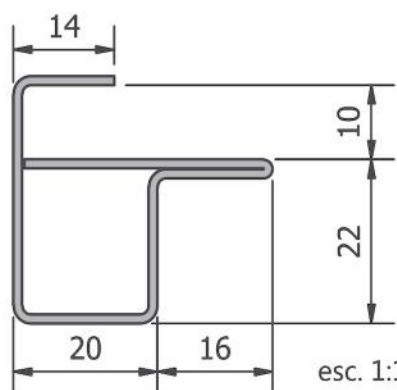

esc. 1:1

CH	COMP.	PESO kg
1,20mm	3000mm	3,78
1,25mm GV	3000mm	3,93

T40 - Perfil cantoneira amassada com aba

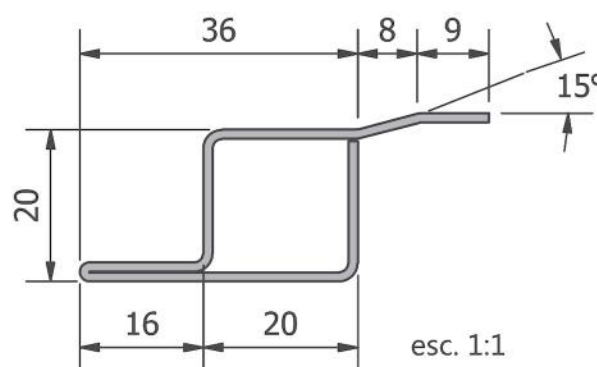

esc. 1:1

CH	COMP.	PESO kg
1,20mm	3000mm	3,66

T41 - Perfil cantoneira amassada com aba

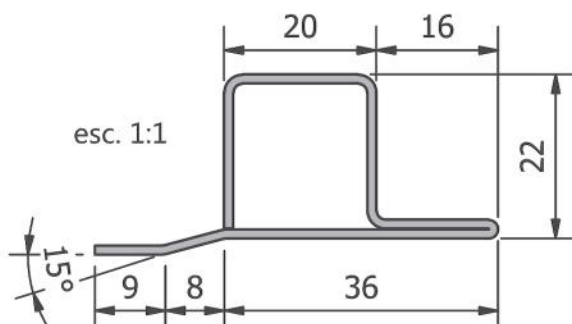

esc. 1:1

CH	COMP.	PESO kg
1,20mm	3000mm	3,66

DICA

Utilize o Arame Mig para solda de qualidade. Consulte nossa linha no catálogo de Acessórios, vide página 90.



Perfil para janela linha 25

T29 - Perfil T amassado

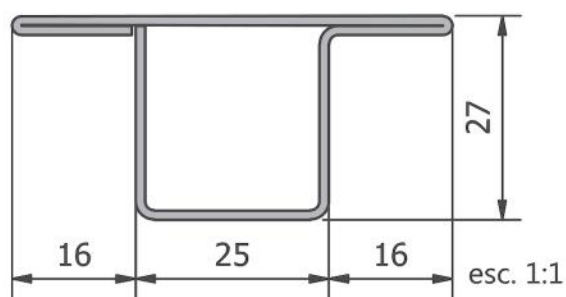

CH	COMP.	PESO kg
1,20mm	3000mm	4,68
1,55mm GV	3000mm	5,95

T43 - Perfil cantoneira amassada

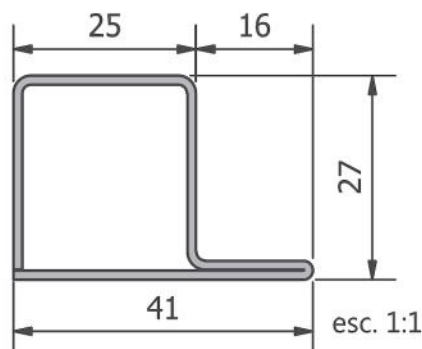

CH	COMP.	PESO kg
1,20mm	3000mm	3,70
1,50mm	3000mm	4,60
1,25mm GV	3000mm	3,70

T32 - Perfil F amassado

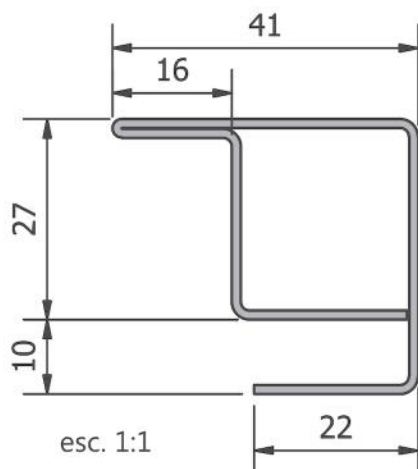

CH	COMP.	PESO kg
1,20mm	3000mm	4,62

T33 - Perfil F amassado

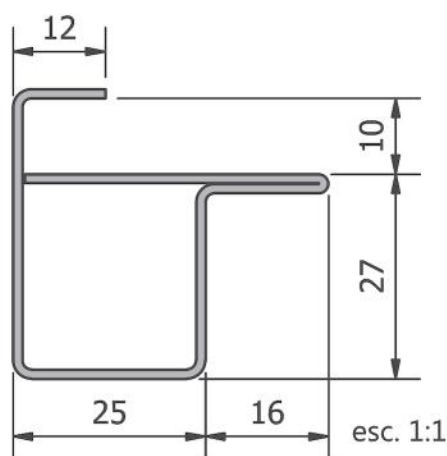

CH	COMP.	PESO kg
1,20mm	3000mm	4,33

T37 - Perfil cantoneira amassada

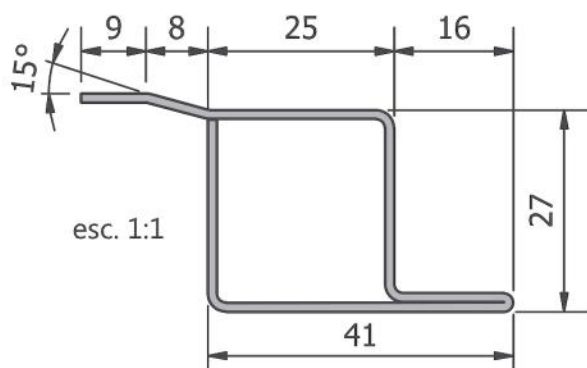

CH	COMP.	PESO kg
1,20mm	3000mm	4,24



DICA

Utilize o disco de corte para maior precisão no corte das peças. Consulte nossa linha no catálogo de acessórios vide página 102.

Perfil para janela linha 40 e 50

T31 - Perfil T amassado

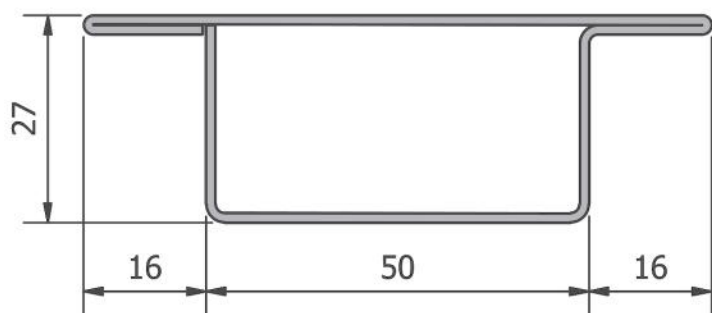

esc. 1:1

CH	COMP.	PESO kg
1,20mm	3000mm	6,15



T45 - Perfil cantoneira amassada

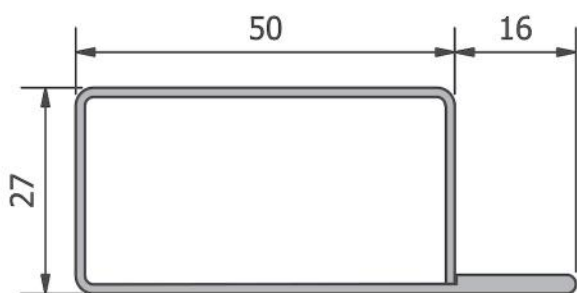

esc. 1:1

CH	COMP.	PESO kg
1,20mm	3000mm	5,20
1,50mm	3000mm	6,40
1,25mm GV	3000mm	5,25

DICA

Utilize os perfis da linha 40 e 50 para maior resistência em grandes vãos.



T67 - Perfil cantoneira amassada

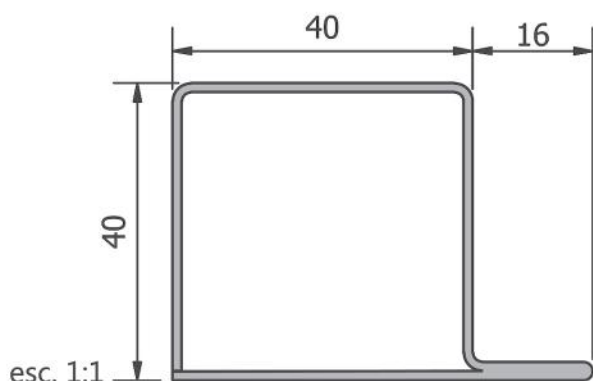

esc. 1:1

CH	COMP.	PESO kg
1,20mm	3000mm	5,36



Perfil para janela linha 40 e 50

T183 - Perfil T amassado

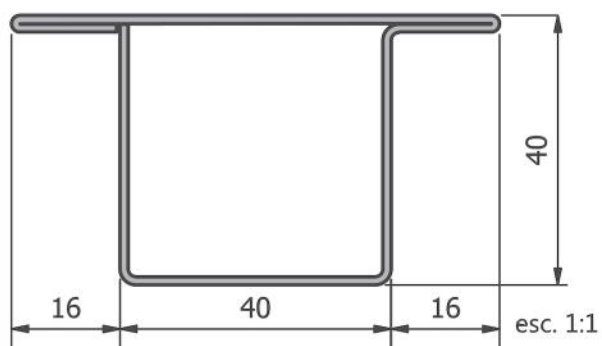

CH	COMP.	PESO kg
1,20mm	3000mm	6,11

T38 - Perfil cantoneira amassada com aba

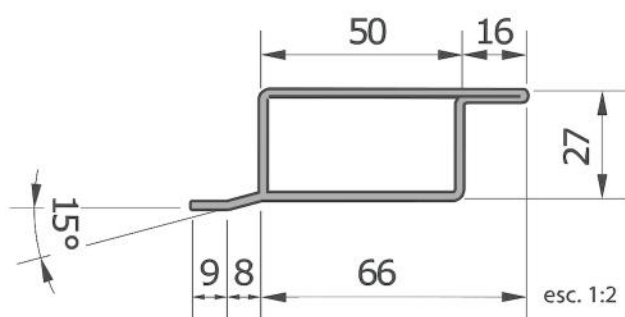

DICA

Utilize os perfis da linha 40 e 50 para maior resistência em grandes vãos.

CH	COMP.	PESO kg
1,50mm	3000mm	7,03

T184 - Perfil cantoneira amassada

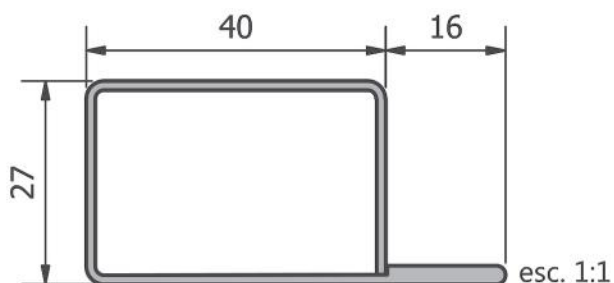

CH	COMP.	PESO kg
1,20mm	3000mm	4,45
1,50mm	3000mm	5,48
2,00mm	3000mm	7,29
1,25mm GV	3000mm	4,63

Perfil para janela linha 50 e outros

T39 - Perfil T amassado

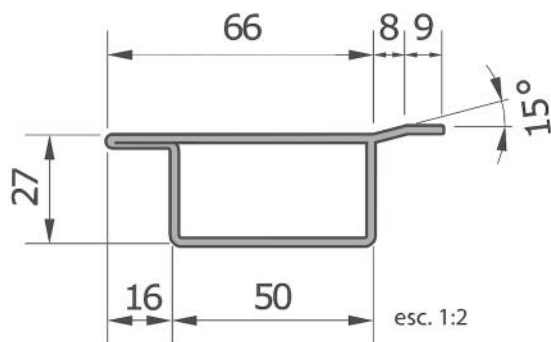

CH	COMP.	PESO kg
1,50mm	3000mm	7,03

T46 - Perfil cantoneira amassada

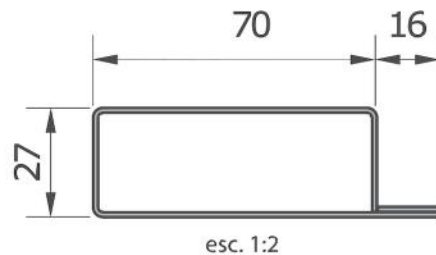

CH	COMP.	PESO kg
1,20mm	3000mm	6,38

T47- Perfil cantoneira amassada

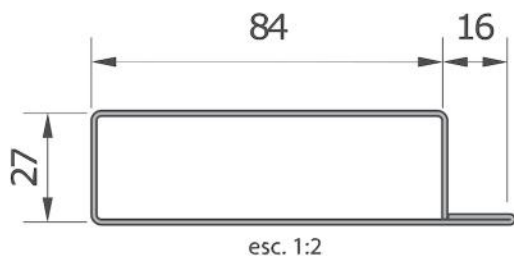

CH	COMP.	PESO kg
1,20mm	3000mm	7,17



T58 - Perfil cantoneira

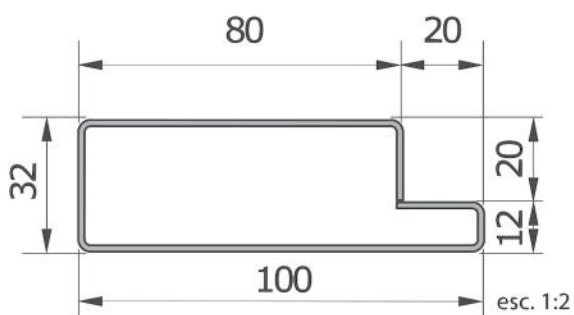

CH	COMP.	PESO kg
1,50mm	3000mm	9,20

DICA



Utilize os perfis da linha 40 e 50 para maior resistência em grandes vãos.

Perfil para janela maximar

T13 - Perfil Z amassado

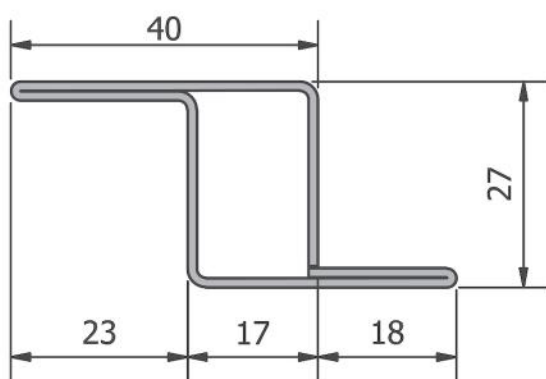

esc. 1:1

CH	COMP.	PESO kg
1,20mm	3000mm	4,61



T30 - Perfil T amassado

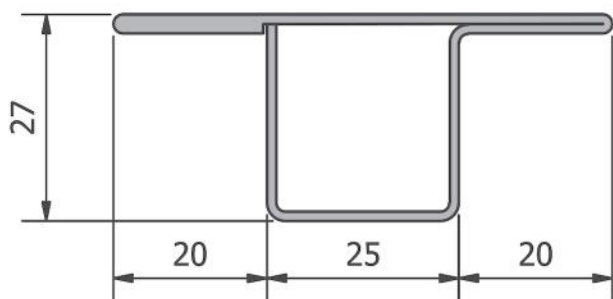

esc. 1:1

CH	COMP.	PESO kg
1,20mm	3000mm	5,15

DICA

As janelas maximoar permitem maior abertura e ventilação.



T44 - Perfil cantoneira amassada

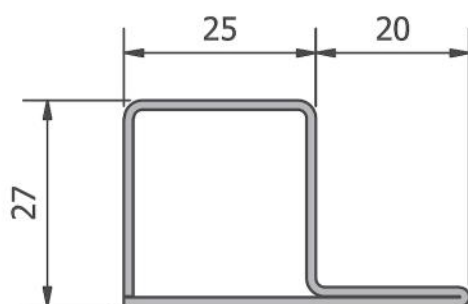

esc. 1:1

CH	COMP.	PESO kg
1,20mm	3000mm	4,01



Marco para porta

•Marco para porta

FAMÍLIA MARCO PARA PORTA

O marco de porta, também chamado de batente de porta, é instalado na parte interna da parede para sustentação de portas, permitindo a abertura e o fechamento com segurança e praticidade.

A Tévere disponibiliza estes perfis em aço Fina Frio, Fina Quente e Galvanizado, garantindo excelência e qualidade nas dobras e no acabamento final.

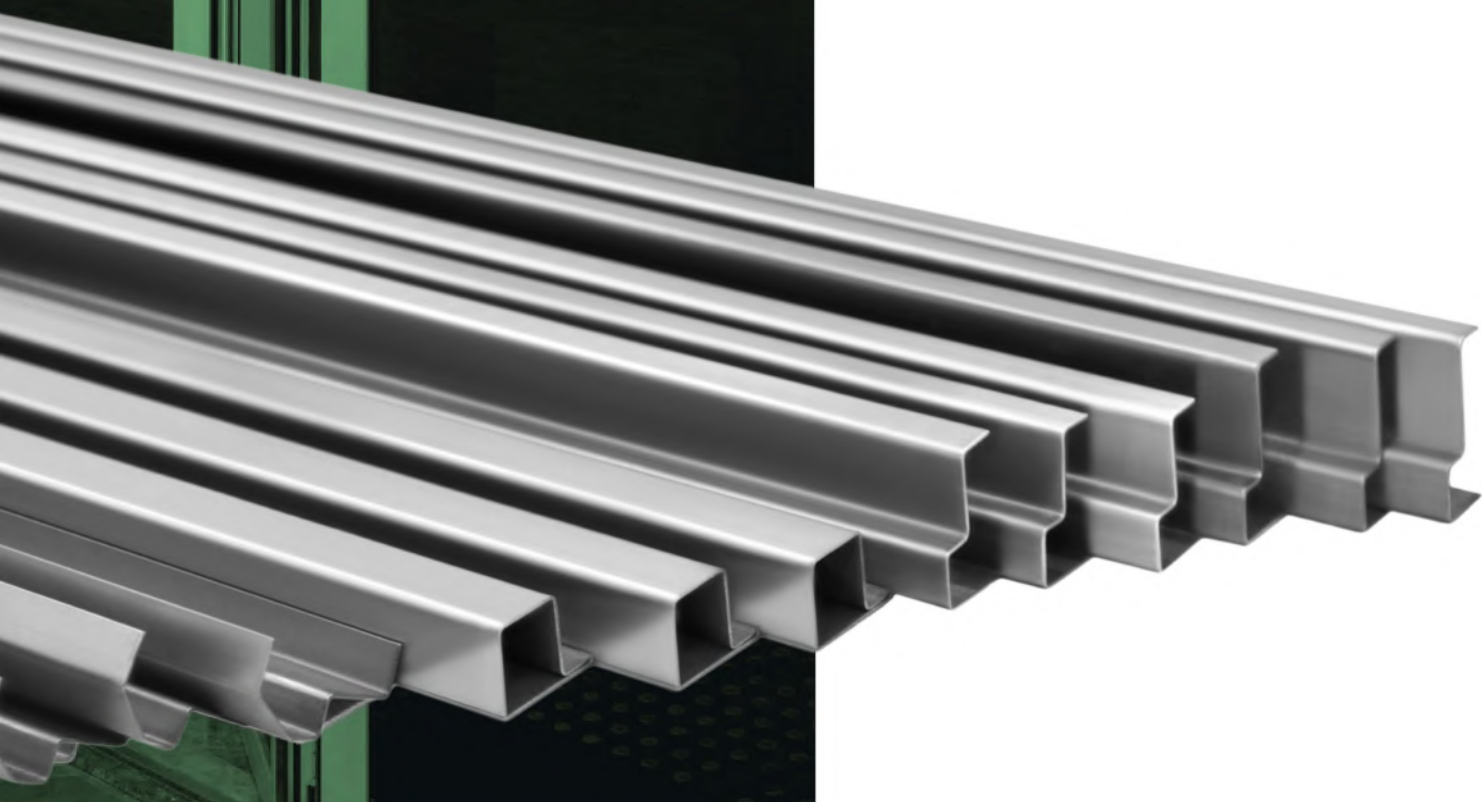

Marco para porta

T89 - Marco para porta

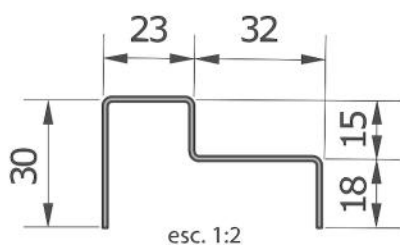

CH	COMP.	PESO kg
1,20mm	2300mm	2,54
1,20mm	3000mm	3,31
1,50mm	2300mm	3,15
1,50mm	3000mm	4,06
2,00mm	2300mm	4,20
2,00mm	3000mm	5,40

T56 - Marco para porta

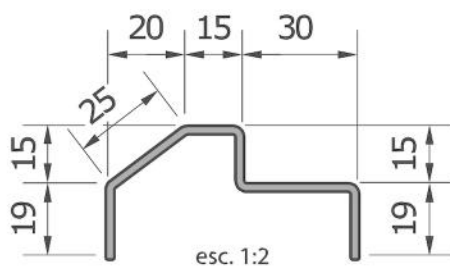

CH	COMP.	PESO kg
1,20mm	2300mm	2,60
1,20mm	3000mm	3,39
1,50mm	2300mm	3,20
1,50mm	3000mm	4,17
2,00mm	3000mm	6,26

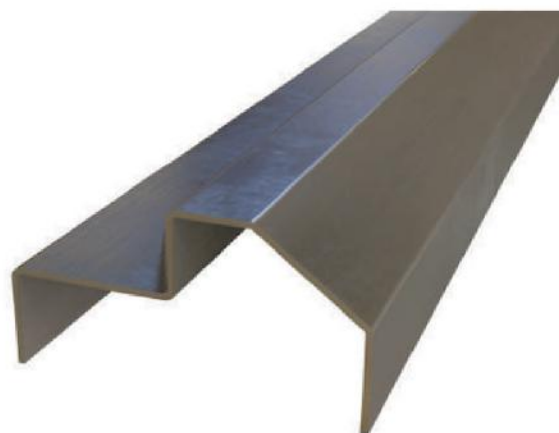

T66 - Marco para porta

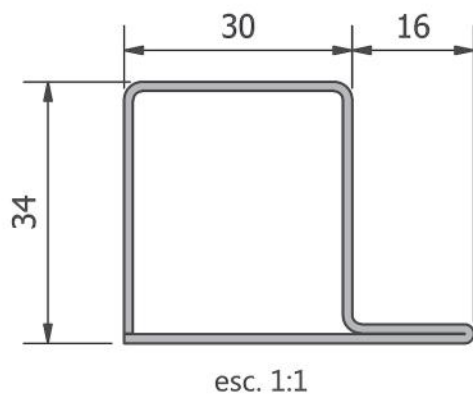

CH	COMP.	PESO kg
1,20mm	3000mm	4,19
1,50mm	3000mm	5,10



DICA

Utilize os acessórios para o conjunto de porta:

- Dobradiça
- Fechadura
- Puxador

Trilhos

- Trilhos diversos
- Tampas diversas

FAMÍLIA TRILHOS

Os trilhos e tampas são usados normalmente para portas, janelas e grades de proteção. Há possibilidade de deixar o trilho aparente, deixando um aspecto robusto, mantendo o ambiente com um ar moderno e elegante.

As portas de correr por exemplo, podem permitir a integração de ambientes, além de deixar o local com uma sensação de amplitude maior.

É uma excelente escolha para projetos onde se busca a otimização do espaço. Encontre a solução que você precisa contando com nossos produtos, utilizando o mais adequado para seu ambiente.

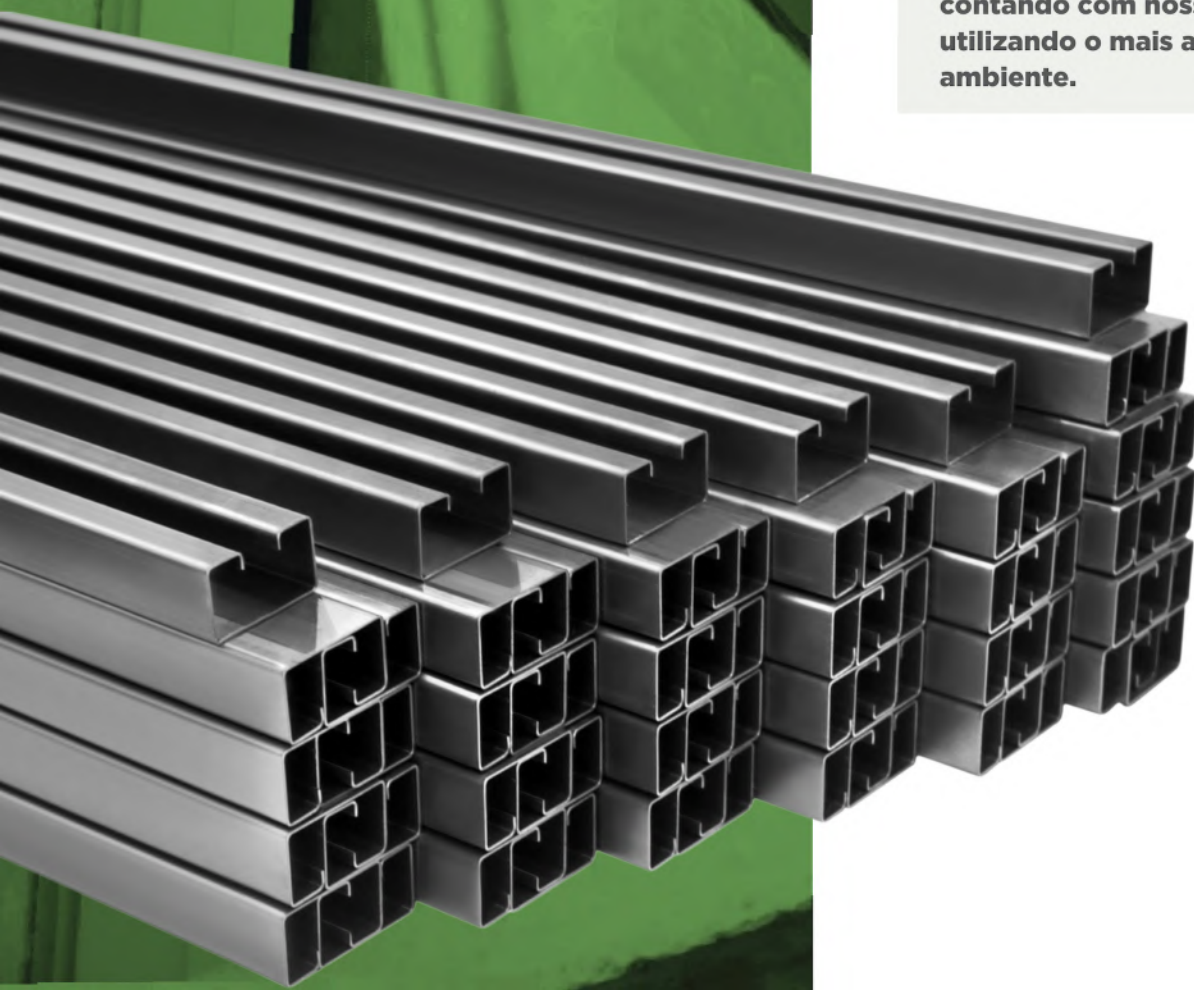

Trilhos diversos

T85 - Trilho superior

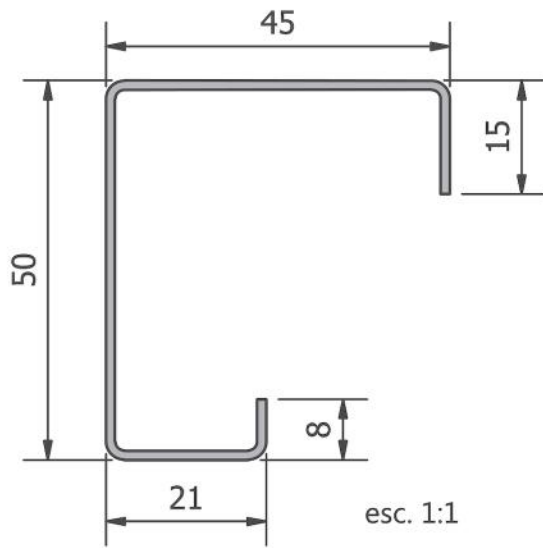

CH	COMP.	PESO kg
1,20mm	3000mm	3,77
1,50mm	3000mm	4,66

T86 - Trilho superior

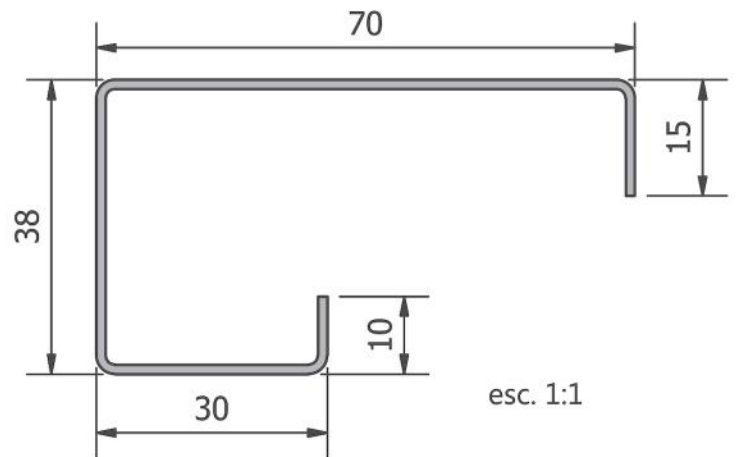

CH	COMP.	PESO kg
1,20mm	3000mm	4,48

T87 - Trilho superior

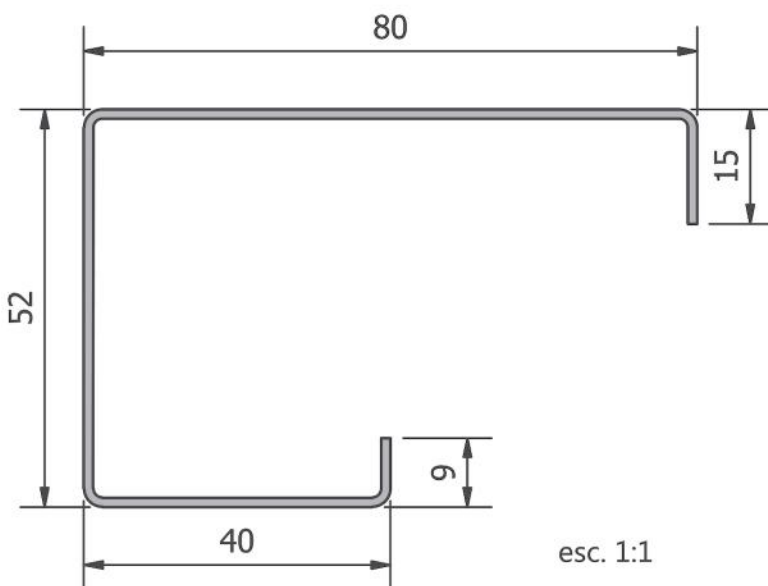

CH	COMP.	PESO kg
1,20mm	3000mm	5,44



Tampas diversas

T148 - Tampa amassada

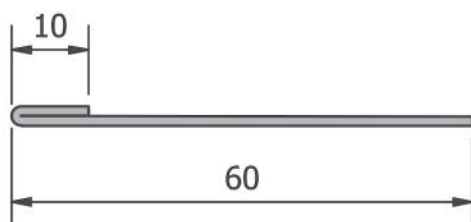

esc. 1:1

CH	COMP.	PESO kg
1,20mm	3000mm	1,98



T149 - Tampa amassada

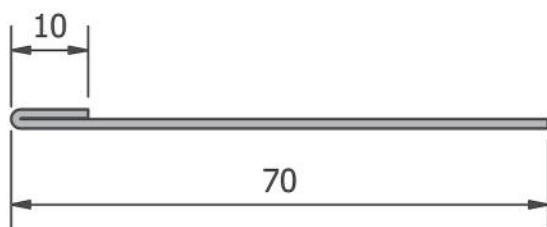

esc. 1:1

CH	COMP.	PESO kg
1,20mm	3000mm	2,26

T150 - Tampa em I

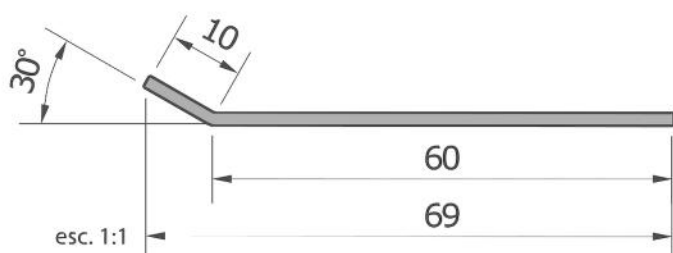

esc. 1:1

CH	COMP.	PESO kg
1,20mm	3000mm	1,98



DICA

Possuímos diversas opções de tampas e trilhos em nossa linha de produtos. Opções utilizadas em porta de correr e janelas, mantendo agilidade na abertura e fechamento, com isso conseguimos atender as exigências de nossos clientes. Solicite seu orçamento!



Trilhos

T185 - Trilho superior

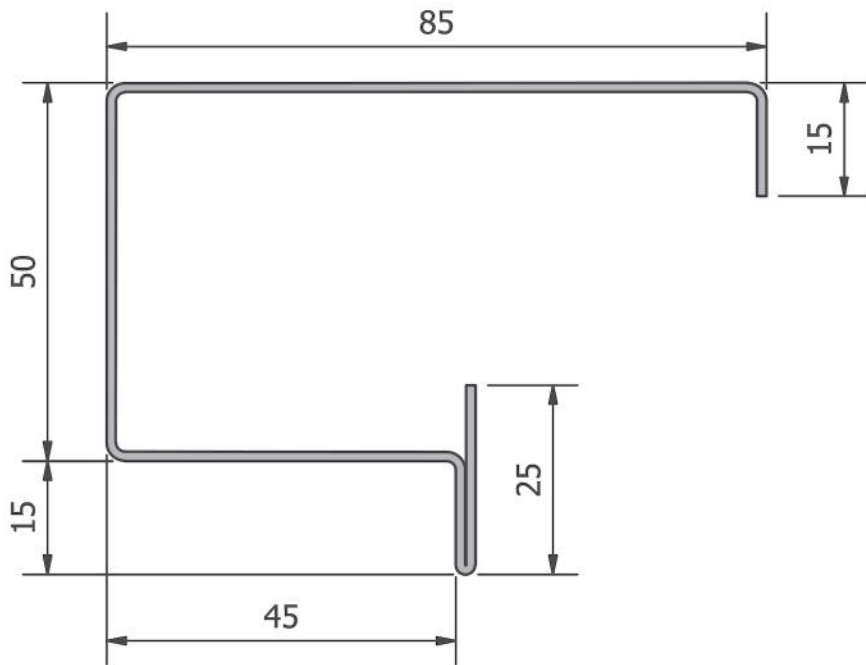

esc. 1:1

CH	COMP.	PESO kg
1,20mm	3000mm	6,43
1,50mm	3000mm	7,58



Conjunto de Elevação

- Conj. de elevação de 120 mm
- Conj. de elevação de 140 mm
- Conj. de elevação de 150 mm
- Conj. de elevação de 160 mm
+ trilhos embutidos
- Conj. de elevação de 180 mm
- Conj. de elevação de 200 mm
+ trilhos embutidos
- Tampas rebaixadas
- Negativas
- Trilho para coluna de elevação
- Batentes

FAMÍLIA CONJUNTO DE ELEVAÇÃO

Os conjuntos de elevação são materiais para fabricação de portões basculantes e de elevação. Geralmente é instalado em aberturas de casas e garagens. O produto acabado, além de moderno, permite agilidade e segurança na sua utilização.

A Tévere possui tradição na produção dos materiais necessários para a fabricação do kit. A variedade de medidas e de espessuras, o uso de materiais como chapas Fina Frio, Fina Quente e Galvanizado, possibilitam ampliar as opções de aplicação. O acabamento de nossos materiais, a uma execução bem feita, são os diferenciais para um ótimo acabamento do produto final.

Conjunto de elevação de 120 mm

T120 - Caixa

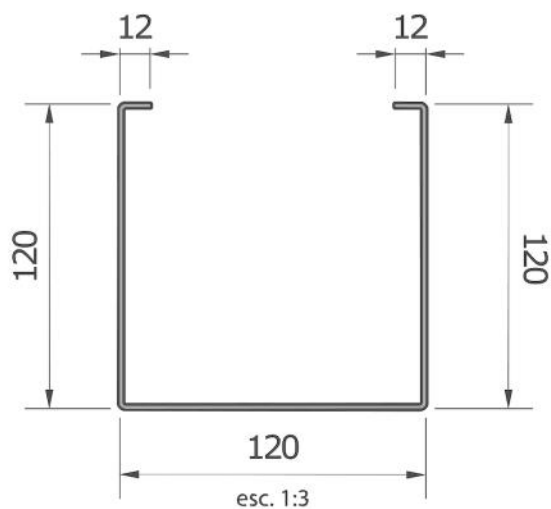

CH	COMP.	PESO kg
1,20mm	2300mm	8,12
1,20mm	2500mm	8,84
1,20mm	3000mm	10,60
1,50mm	2300mm	10,14
1,50 mm	2500mm	11,10
1,25mm GV	2300mm	8,36
1,25mm GV	3000mm	11,10
1,55mm GV	3000mm	13,60

T120A - Tampa em L

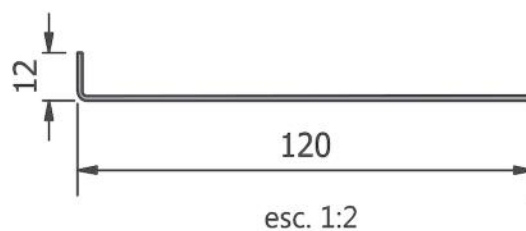

CH	COMP.	PESO kg
1,20mm	2300mm	2,83
1,20mm	2500mm	3,10
1,20mm	3000mm	3,70
1,50mm	2300mm	3,52
1,50mm	2500mm	3,90
1,50mm	3000mm	4,60
1,25mm GV	2300mm	2,92
1,25mm GV	2500mm	3,20
1,55mm GV	3000mm	3,81

T121A - Tampa em U

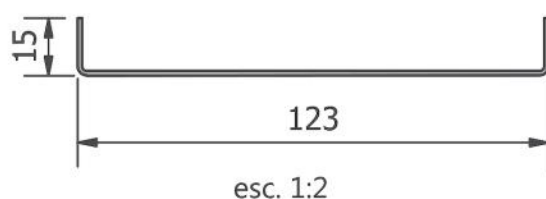

CH	COMP.	PESO kg
1,20mm	2300mm	3,34
1,25mm GV	2300mm	3,48
1,25mm GV	2500mm	3,78
1,25mm GV	3000mm	4,54
1,55mm GV	2300mm	4,32



Dica

Temos opção de tampas em outros modelos, vide página 54.



Conjunto de elevação de 120 mm

T121 - Viga de cima com batente

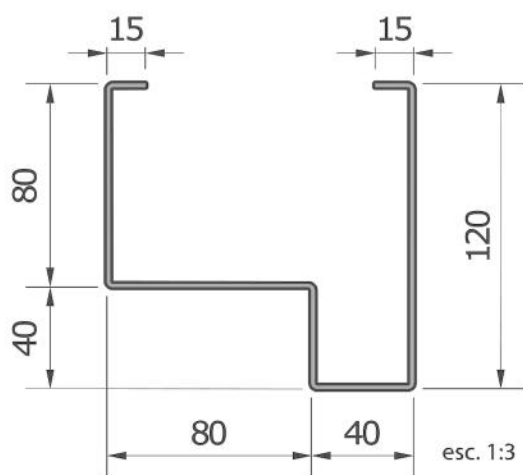

CH	COMP.	PESO kg
1,20mm	3000mm	10,50
1,50mm	3000mm	13,40
1,55mm GV	3000mm	13,80

T115 - Tubo para peso

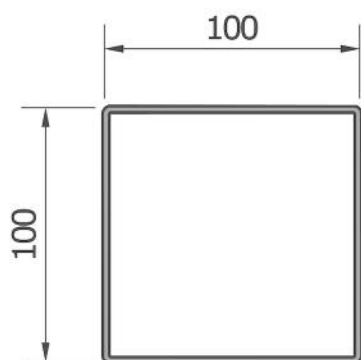

esc. 1:3

CH	COMP.	PESO kg
1,20mm	3000mm	11,02
1,50mm	3000mm	13,77
2,00mm	3000mm	18,46
1,25mm GV	3000mm	11,55
1,55mm GV	3000mm	14,18

T181 - Viga de cima sem batente

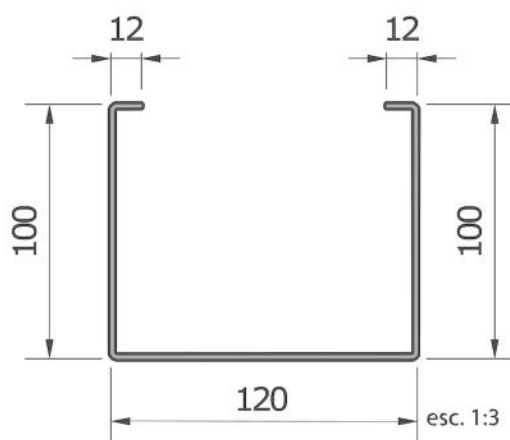

CH	COMP.	PESO kg
1,20mm	3000mm	9,63
1,50mm	3000mm	11,89



DICA

Utilize os acessórios para o conjunto de porta, como:

- Roldanas (ferro e nylon)(ACE)
- Pino guia (ACE)
- Cabo de aço (ACE)
- Clips para cabo de aço (ACE)
- Granalha para contra peso

Conjunto de elevação de 140 mm

T92 - Caixa

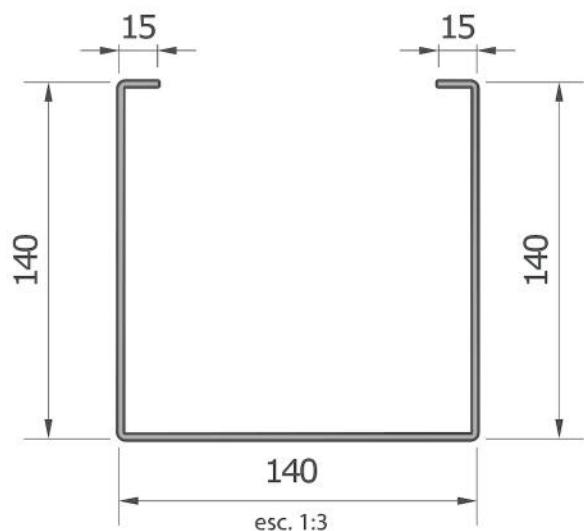

CH	COMP.	PESO kg
1,20mm	2300mm	9,60
1,20mm	2500mm	10,50
1,20mm	3000mm	12,50
1,50mm	2300mm	12,30
1,50mm	2500mm	13,35
1,50mm	3000mm	16,03
2,00mm	2300mm	16,20
2,00mm	2500mm	17,40
2,00mm	3000mm	19,86
1,25mm GV	2300mm	10,03
1,25mm GV	2500mm	11,00
1,25mm GV	3000mm	14,38
1,55mm GV	2300mm	12,77

Dica

Pode ser utilizado trilhos (ver pagina 55) :

- T91
- T137

T92A - Tampa em L

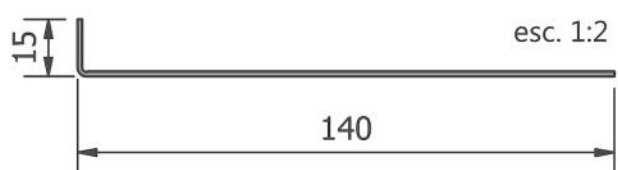

CH	COMP.	PESO kg
1,20mm	2300mm	3,31
1,20mm	2500mm	3,60
1,20mm	3000mm	4,33
1,50mm	2300mm	4,12
1,50mm	2500mm	4,48
1,50mm	3000mm	5,37
1,25mm GV	2300mm	3,46
1,25mm GV	2500mm	3,78

T122A - Tampa em U

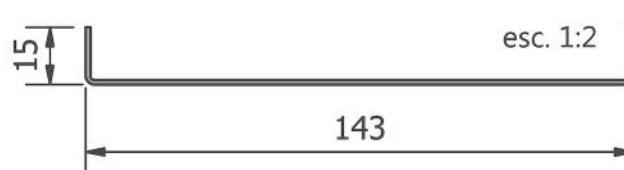

CH	COMP.	PESO kg
1,20mm	2300mm	3,80
1,20mm	2500mm	4,13
1,20mm	3000mm	4,75
1,50mm	2300mm	4,67
1,50mm	3000mm	6,00

Dica

Temos opção de tampas em outros modelos, vide pagina 54.

Conjunto de elevação de 140 mm

T122 - Viga de cima com batente

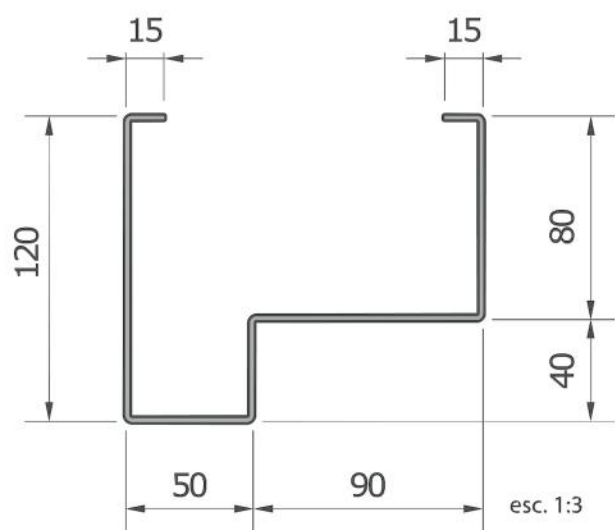

CH	COMP.	PESO kg
1,20mm	3000mm	11,65
1,50mm	3000mm	13,95

T127 - Viga de cima sem batente

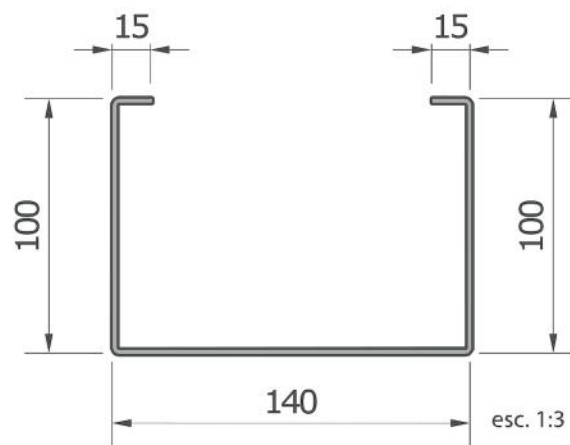

CH	COMP.	PESO kg
1,20mm	3000mm	10,17
1,50mm	3000mm	12,71

T182 - Tubo para peso

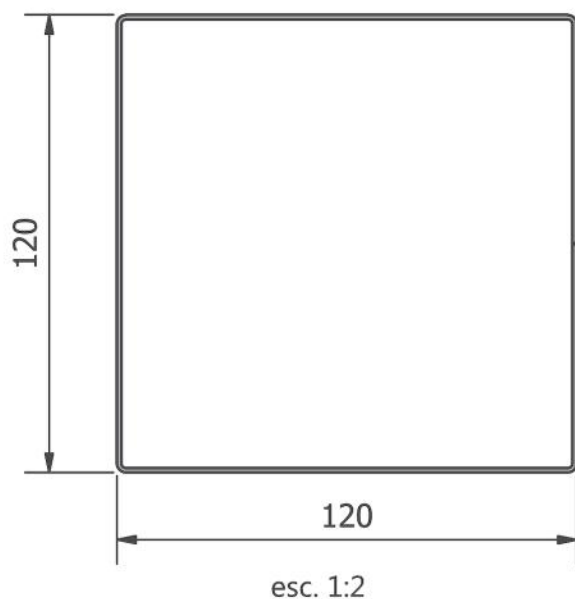

CH	COMP.	PESO kg
1,20mm	3000mm	13,30
1,50mm	3000mm	16,60



Dica

Consulte nossa linha de tubos para fabricação do quadro de portão.



Conjunto de elevação de 150 mm

T94 - Caixa

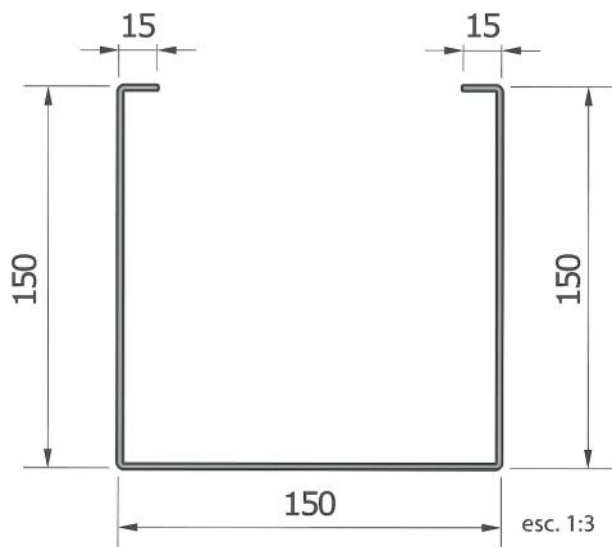

CH	COMP.	PESO kg
1,20mm	2300mm	10,56
1,20mm	2500mm	11,48
1,20mm	3000mm	13,76
1,50mm	2300mm	13,13
1,50mm	2500mm	14,28
1,50mm	3000mm	17,13
2,00mm	2300mm	17,10
2,00mm	2500mm	18,50
2,00mm	3000mm	22,30
1,25mm GV	2300mm	11,04
1,25mm GV	2500mm	12,00
1,25mm GV	3000mm	14,38
1,55mm GV	2300mm	13,77
1,55mm GV	2500mm	14,78
1,55mm GV	3000mm	17,13

Dica

Pode ser utilizado trilhos (ver pagina 55) :

- T91
- T137

T94A - Tampa em L

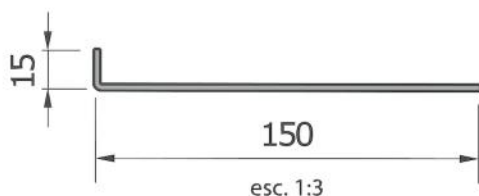

CH	COMP.	PESO kg
1,20mm	2300mm	3,54
1,20mm	2500mm	3,85
1,20mm	3000mm	4,61
1,50mm	2300mm	4,39
1,50mm	2500mm	4,78
1,50mm	3000mm	5,73
2,00mm	2300mm	6,20
1,25mm GV	2300mm	3,70
1,25mm GV	2500mm	4,02
1,25mm GV	3000mm	4,82
1,55mm GV	3000mm	5,93

T123A - Tampa em U

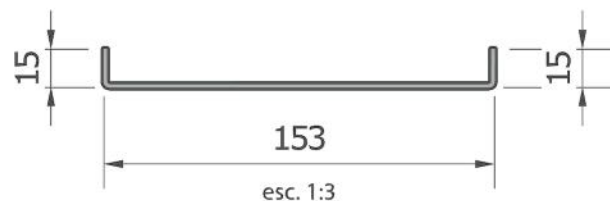

CH	COMP.	PESO kg
1,20mm	2300mm	3,87
1,20mm	2500mm	4,21
1,20mm	3000mm	5,03
1,50mm	2300mm	4,95
1,50mm	2500mm	5,38
1,50mm	3000mm	6,30
1,25mm GV	2300mm	4,05
1,25mm GV	2500mm	4,40
1,25mm GV	3000mm	5,28

Dica

Temos opção de tampas em outros modelos, vide página 54.

Conjunto de elevação de 150 mm

T123 - Viga de cima com batente

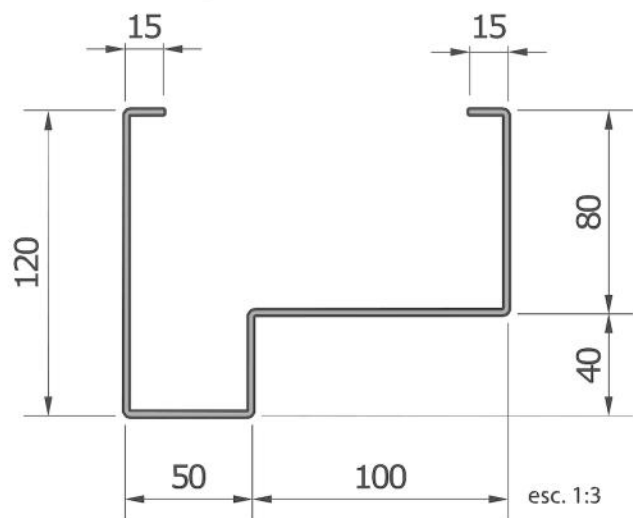

CH	COMP.	PESO kg
1,20mm	2300mm	8,85
1,20mm	2500mm	10,00
1,20mm	3000mm	11,50
1,50mm	3000mm	14,35

T128 - Viga de cima sem batente

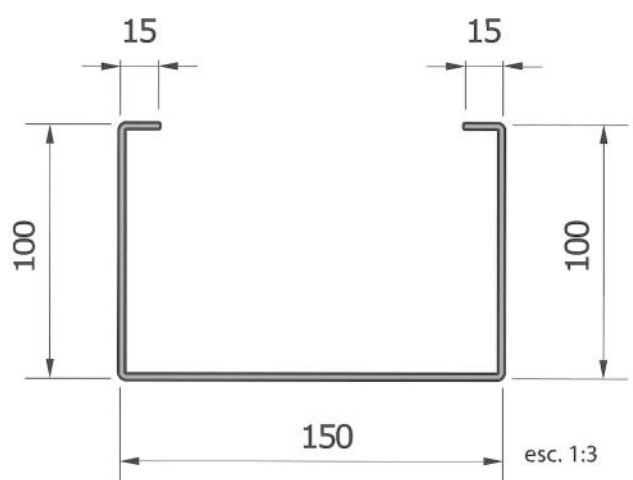

T116 - Tubo para peso

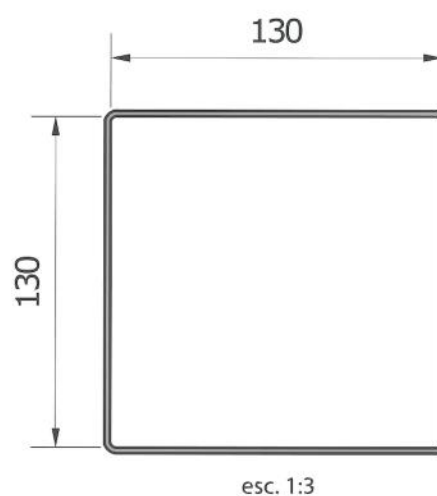

CH	COMP.	PESO kg
1,20mm	3000mm	10,50
1,50mm	3000mm	13,06
1,25mm GV	3000mm	10,97

CH	COMP.	PESO kg
1,20mm	3000mm	14,41
1,50mm	3000mm	18,02
1,25mm GV	3000mm	15,06
1,55mm GV	3000mm	18,65

Conjunto de elevação de 160 mm

T95 - Caixa

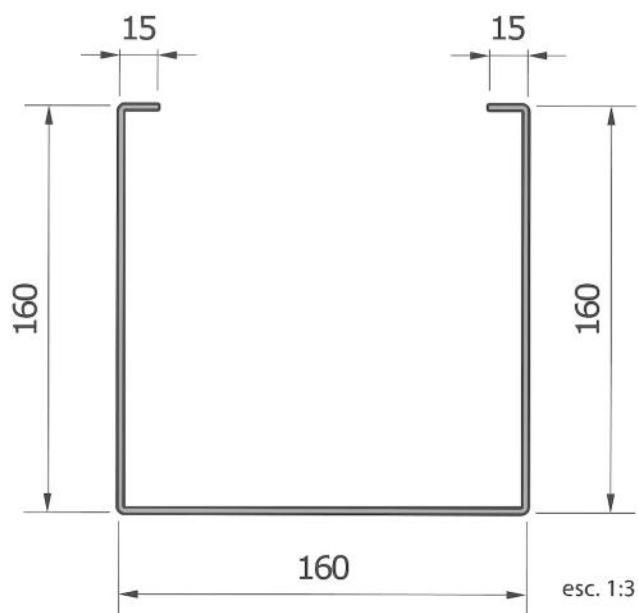

CH	COMP.	PESO kg
1,20mm	2300mm	10,90
1,20mm	2500mm	12,20
1,20mm	3000mm	14,64
1,50mm	2300mm	14,00
1,50mm	2500mm	15,20
1,50mm	3000mm	18,23
2,00mm	2300mm	17,80
2,00mm	2500mm	19,50
2,00mm	3000mm	23,80
1,25mm GV	2300mm	11,04
1,25mm GV	2500mm	12,75
1,25mm GV	3000mm	15,30



Dica

Pode ser utilizado trilhos (ver pagina 55) :

- T91
- T137

T98 - conjunto de elevação de 160mm com trilho embutido

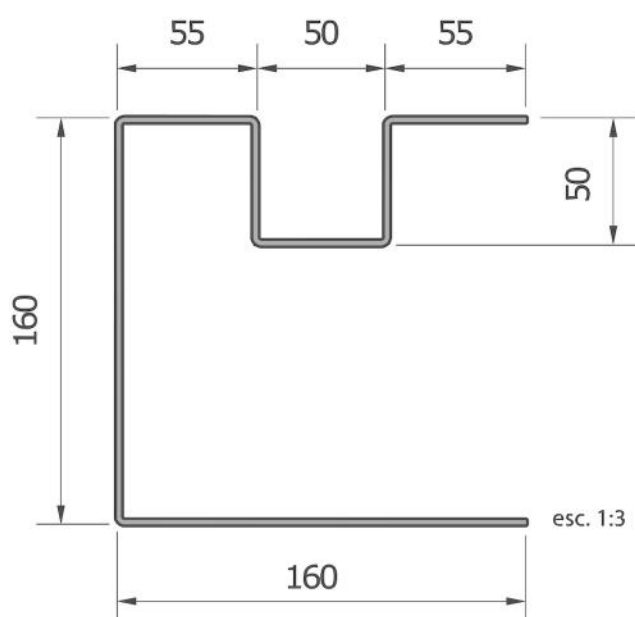

CH	COMP.	PESO kg
1,50mm	2300mm	15,85
1,50mm	2500mm	17,10
1,50mm	3000mm	20,68
2,00mm	3000mm	26,92
1,55mm GV	2300mm	16,33
1,55mm GV	2500mm	17,67
1,55mm GV	3000mm	21,30



Dica

Para maior espaçamento e praticidade utilize o conjunto de elevação com trilho embutido.

Conjunto de elevação de 160 mm

T95A - Tampa em L

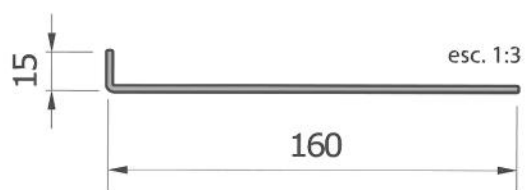

CH	COMP.	PESO kg
1,20mm	2300mm	3,75
1,20mm	2500mm	4,10
1,20mm	3000mm	4,89
1,50mm	2300mm	4,67
1,50mm	2500mm	5,25
1,50mm	3000mm	6,08
1,25mm GV	2300mm	3,92
1,25mm GV	2500mm	4,28
1,25mm GV	3000mm	5,11

T99 - Tampa em U

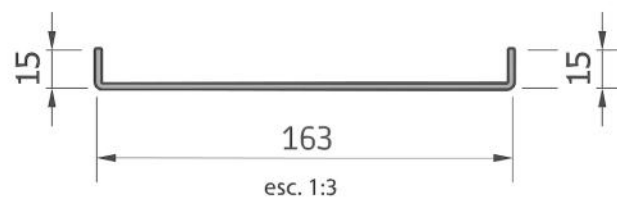

CH	COMP.	PESO kg
1,20mm	2300mm	4,25
1,20mm	2500mm	4,62
1,20mm	3000mm	5,35
1,50mm	2300mm	5,24
1,50mm	2500mm	5,50
1,50mm	3000mm	6,84
1,25mm GV	2300mm	4,43
1,25mm GV	2500mm	4,81
1,25mm GV	3000mm	5,57
1,55mm GV	2300mm	5,41
1,55mm GV	2500mm	5,88
1,55mm GV	3000mm	7,05

Dica

Temos opção de tampas em outros modelos, vide página 54.



T124 - Viga de cima com batente

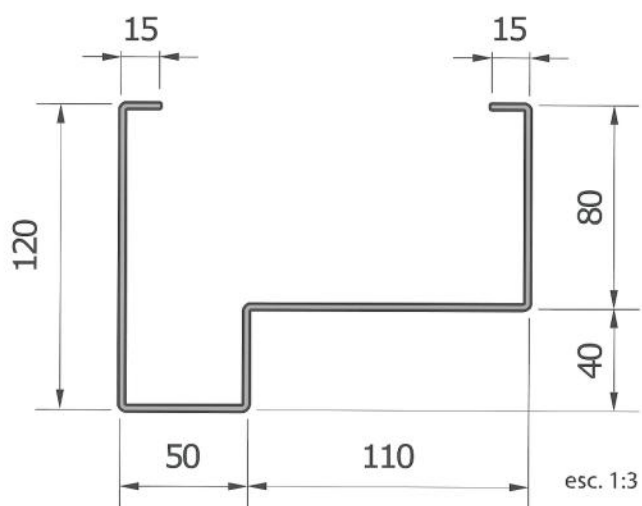

CH	COMP.	PESO kg
1,20mm	3000mm	12,00
1,50mm	3000mm	14,70
1,55mm GV	3000mm	15,34

Conjunto de elevação de 160 mm

T129 - Viga de cima sem batente

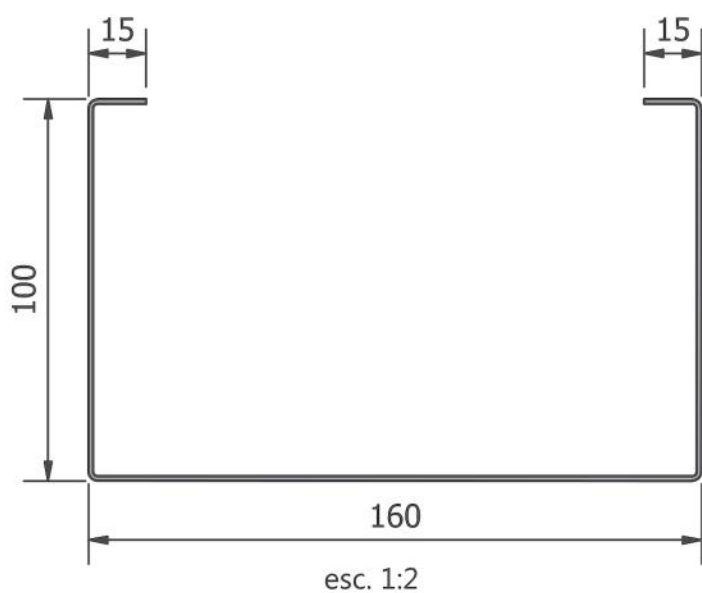

CH	COMP.	PESO kg
1,20mm	3000mm	10,73
1,50mm	3000mm	13,41
1,55mm GV	3000mm	11,21

T117 - Tubo para peso

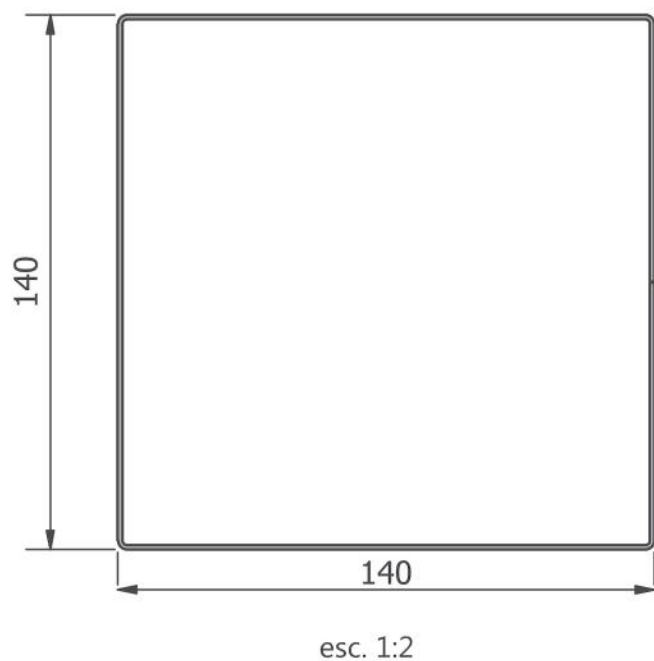

CH	COMP.	PESO kg
1,20mm	3000mm	15,54
1,50mm	3000mm	19,42

Conjunto de elevação de 160 mm

T100 - Contra peso

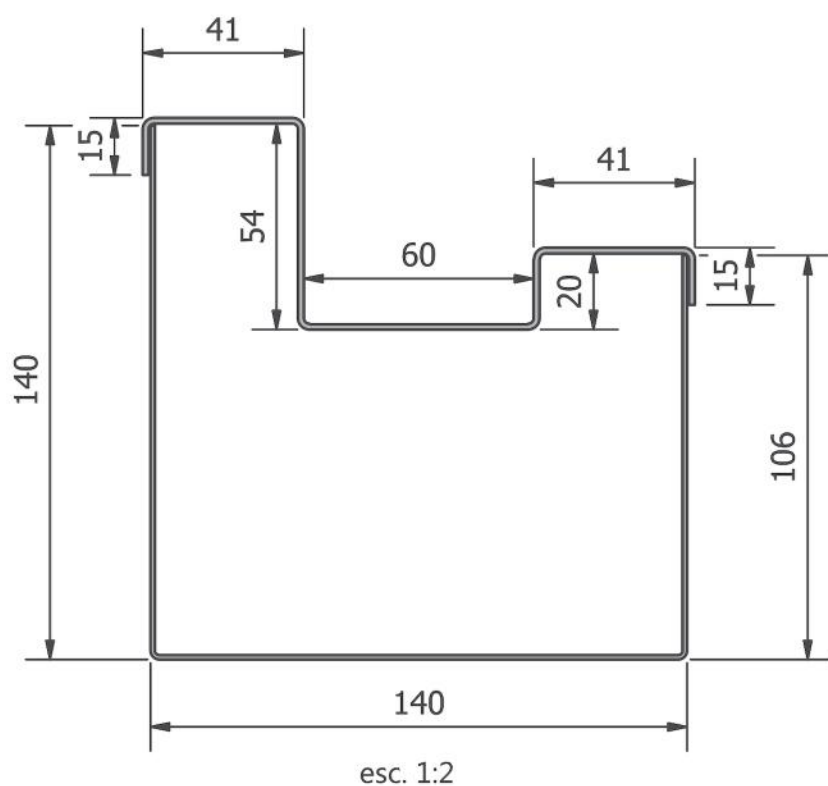

CH	COMP.	PESO kg
	Caixa	
1,20mm	3000mm	
	Tampa	
1,50mm	3000mm	
	Total peso	17,67

DICA

Disponemos de granalha em aço para uso de contrapeso. Consulte-nos!



Conjunto de elevação de 180 mm

T133 - Caixa

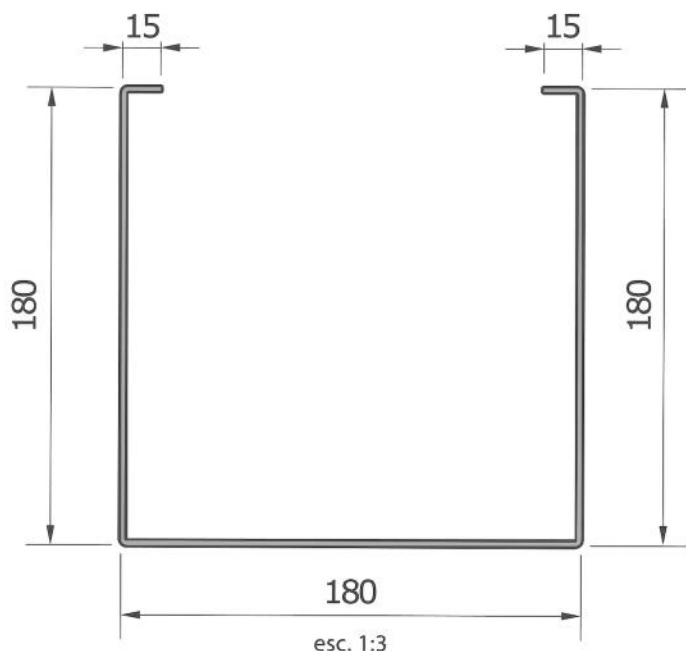

CH	COMP.	PESO kg
1,20mm	2300mm	12,12
1,20mm	2500mm	13,20
1,20mm	3000mm	15,82
1,50mm	2300mm	15,18
1,50mm	2500mm	16,50
1,50mm	3000mm	19,80
2,00mm	2300mm	20,50
2,00mm	2500mm	21,90
2,00mm	3000mm	26,46
1,25mm GV	2300mm	12,67
1,25mm GV	2500mm	13,79
1,25mm GV	3000mm	16,53



Dica

Pode ser utilizado trilhos (ver pagina 55) :

- T91
- T137

T133A - Tampa em L

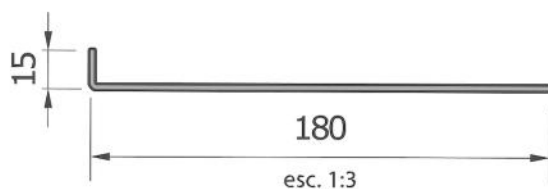

CH	COMP.	PESO kg
1,20mm	2300mm	4,20
1,20mm	2500mm	4,55
1,20mm	3000mm	5,45
1,50mm	2300mm	5,25
1,50mm	2500mm	5,70
1,50mm	3000mm	6,81
1,25mm GV	2300mm	4,39
1,25mm GV	2500mm	4,75

T125A - Tampa em U

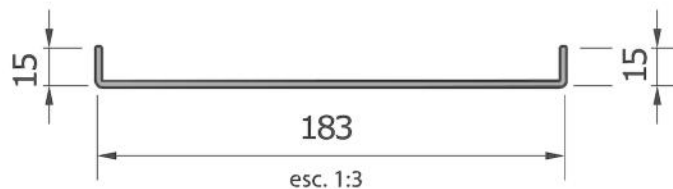

CH	COMP.	PESO kg
1,20mm	2300mm	4,70
1,20mm	2500mm	4,92
1,20mm	3000mm	5,90
1,50mm	2300mm	5,80
1,50mm	2500mm	6,30
1,25mm GV	2300mm	4,70
1,25mm GV	2500mm	5,10
1,25mm GV	3000mm	6,13



Dica

Temos opção de tampas em outros modelos, vide página 54.

Conjunto de elevação de 180 mm

T125 - Viga de cima com batente

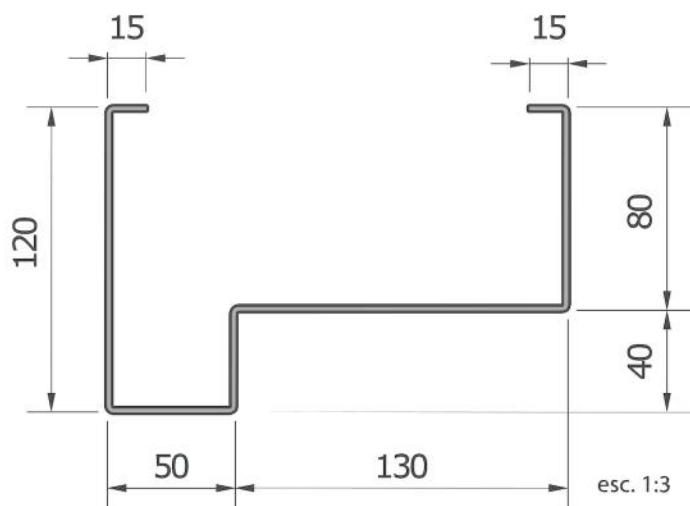

CH	COMP.	PESO kg
1,20mm	3000mm	12,82
1,50mm	3000mm	15,40
1,25mm GV	3000mm	12,79

T130 - Viga de cima sem batente

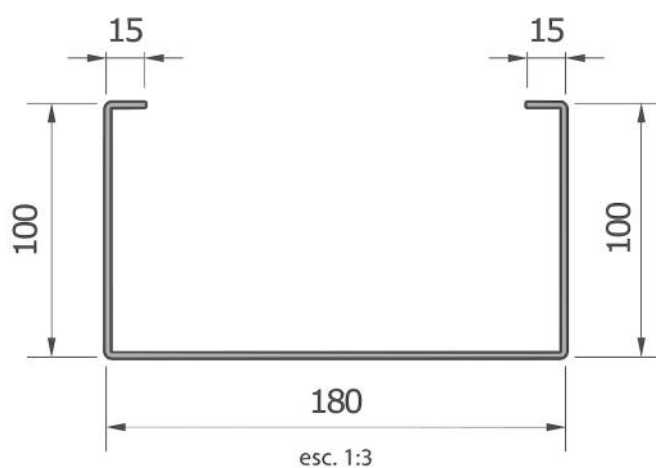

CH	COMP.	PESO kg
1,20mm	3000mm	11,30
1,50mm	3000mm	14,13
1,25mm GV	3000mm	11,81

T118 - Tubo para peso

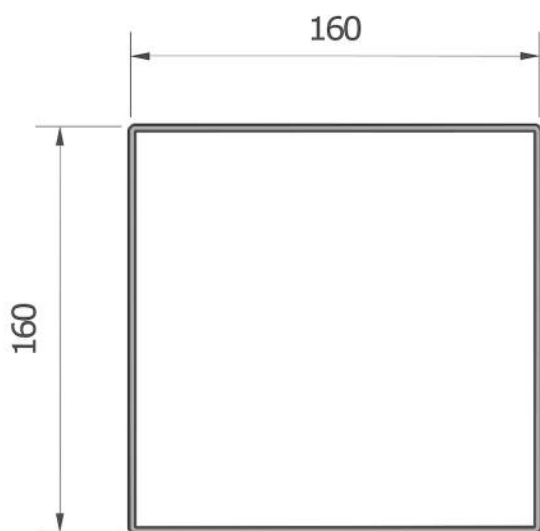

esc. 1:3

CH	COMP.	PESO kg
1,20mm	3000mm	17,80
1,50mm	3000mm	22,25



Dica

Consulte nossa linha de tubos para fabricação do quadro de portão.



Conjunto de elevação de 200 mm

T132 - Caixa

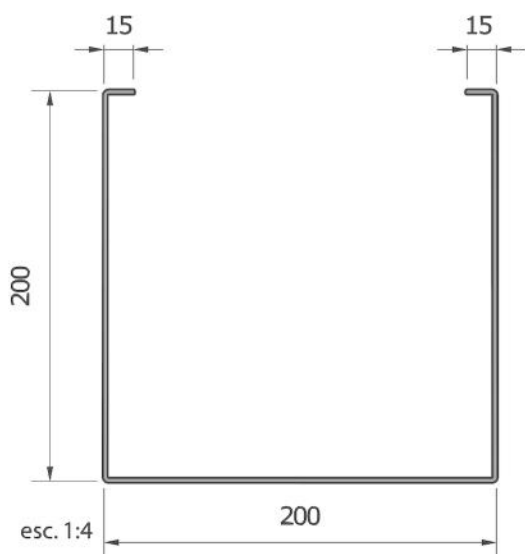

CH	COMP.	PESO kg
1,20mm	2300mm	13,40
1,20mm	2500mm	14,60
1,20mm	3000mm	17,50
1,50mm	2300mm	16,80
1,50mm	2500mm	18,30
1,50mm	3000mm	21,90
2,00mm	2300mm	23,00
2,00mm	2500mm	24,40
2,00mm	3000mm	29,60
1,25mm GV	2300mm	14,00
1,25mm GV	2500mm	15,26
1,25mm GV	3000mm	18,29
1,55mm GV	2300mm	17,39
1,55mm GV	2500mm	18,94
1,55mm GV	3000mm	22,67

T134 - Conjunto de elevação de 200mm com trilho embutido

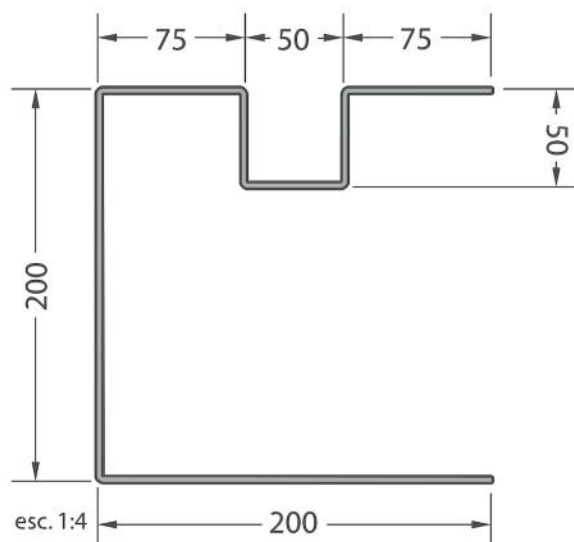

CH	COMP.	PESO kg
1,50mm	2500mm	20,33
1,50mm	3000mm	24,40
2,00mm	3000mm	32,80
1,55 mm GV	2300mm	19,32
1,55 mm GV	2500mm	21,00
1,55 mm GV	3000mm	25,20

T132A - Tampa em L

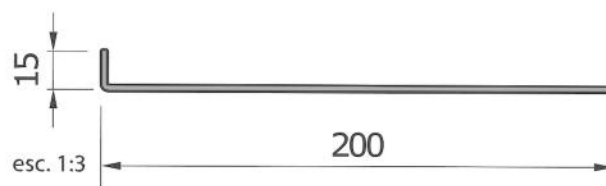

CH	COMP.	PESO kg
1,20mm	2300mm	4,65
1,20mm	2500mm	5,05
1,20mm	3000mm	6,07
1,50mm	2300mm	5,80
1,50mm	2500mm	6,40
1,50mm	3000mm	7,60
2,00mm	3000mm	10,00
1,55mm GV	2300mm	6,00
1,55mm GV	2500mm	6,62

T126A - Tampa em U

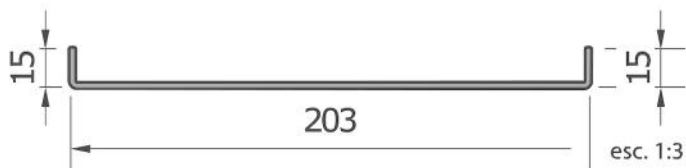

CH	COMP.	PESO kg
1,20mm	2300mm	5,20
1,20mm	2500mm	5,60
1,20mm	3000mm	6,45
1,50 mm	2300mm	6,35
1,50mm	2500mm	6,80
1,50mm	3000mm	8,15
1,25mm GV	3000mm	6,74
1,25mm GV	2500mm	7,00

Conjunto de elevação de 200 mm

T126 - Viga de cima com batente

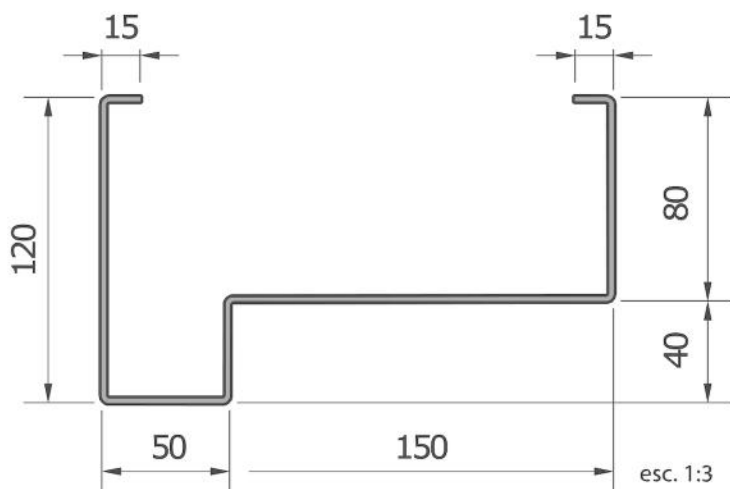

CH	COMP.	PESO kg
1,50mm	3000mm	16,08

T119 - Tubo para peso

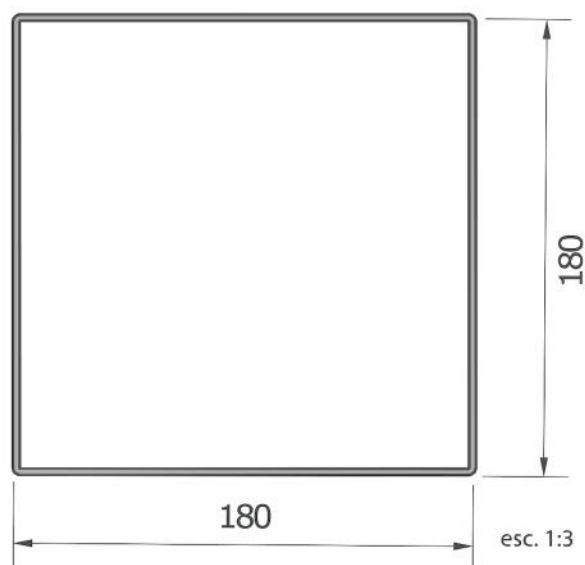

CH	COMP.	PESO kg
1,20mm	3000mm	20,00
1,50mm	3000mm	25,00

T136 - Contra peso

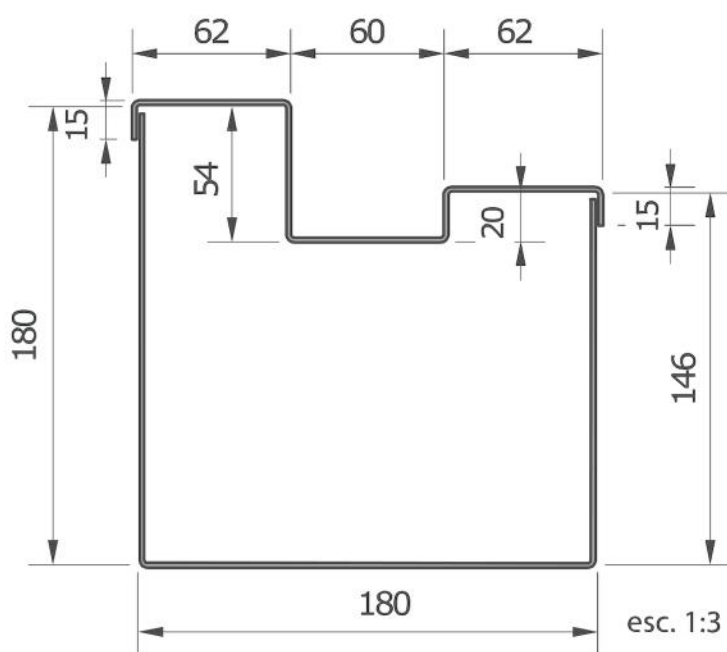

CH	COMP.	PESO kg
1,50mm	3000mm	27,70

T131 - Viga de cima sem batente

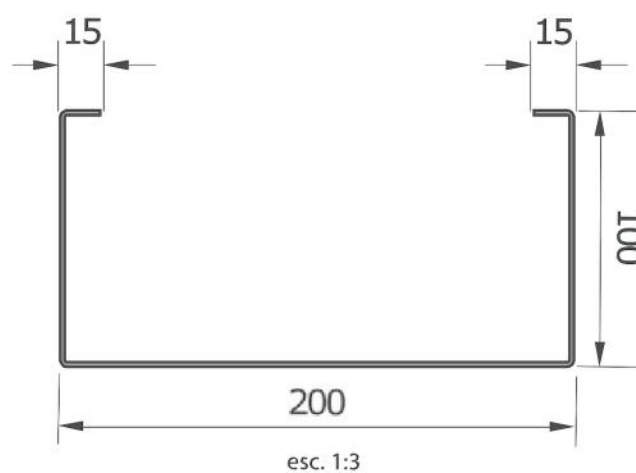

CH	COMP.	PESO kg
1,20mm	3000mm	11,86
1,50mm	3000mm	14,83
1,25mm GV	3000mm	12,39

Tampas rebaixadas

As tampas rebaixadas são muito utilizadas para destaque no design e acabamento de sua caixaaria.

Conheça nossos modelos, tamanhos e espessuras na qual produzimos!

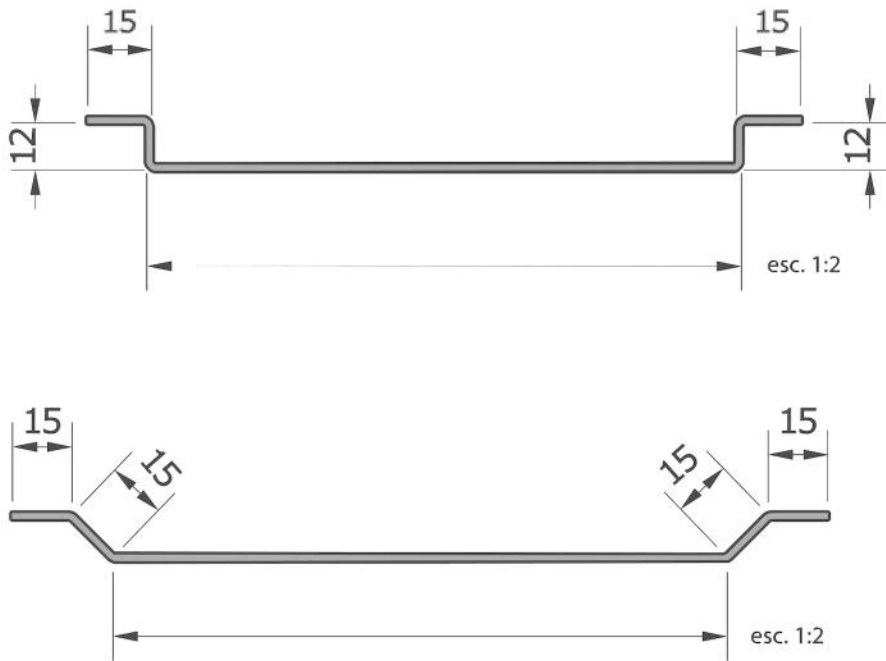

Negativas

Modelos, tamanhos e espessuras conforme solicitação do cliente!

Solicite seu orçamento.

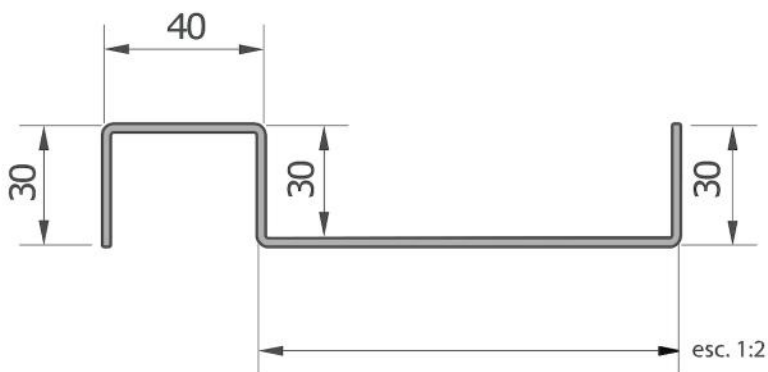

Trilho para coluna de elevação

T91 - Trilho para coluna de elevação T137 - Trilho para coluna de elevação

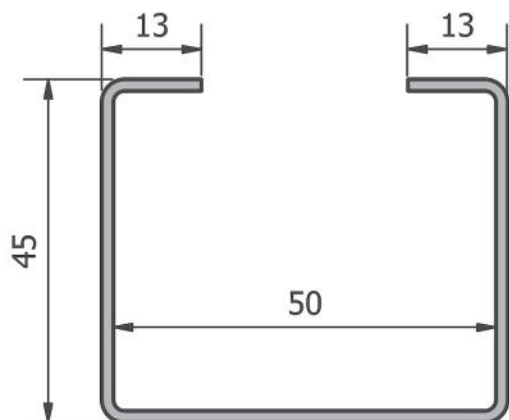

esc. 1:1

CH	COMP.	PESO kg
1,50mm	2300mm	4,32
1,50mm	2500mm	4,70
1,50mm	3000mm	5,63
2,00mm	2300mm	5,70
2,00mm	2500mm	6,16
2,00mm	3000mm	7,40
1,55mm GV	2300mm	4,40
1,55mm GV	2500mm	4,84
1,55mm GV	3000mm	5,80
2,05mm GV	2300mm	5,87
2,05mm GV	2500mm	6,35
2,05mm GV	3000mm	7,45

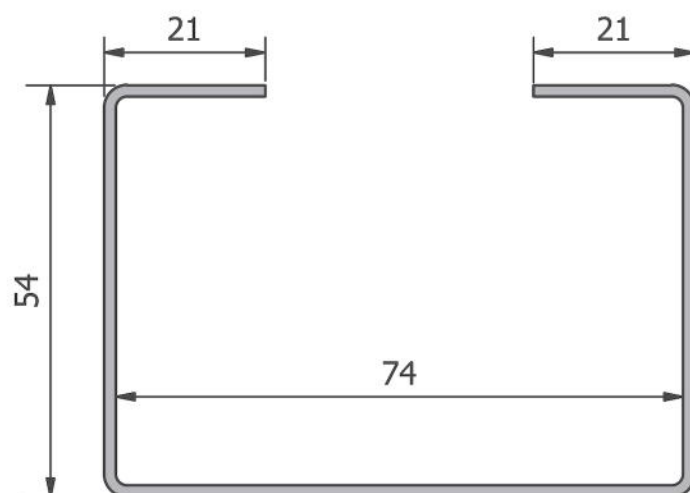

esc. 1:1

CH	COMP.	PESO kg
1,50mm	2300mm	6,05
1,50mm	2500mm	6,57
1,50mm	3000mm	7,88
2,00mm	2300mm	7,80
2,00mm	2500mm	8,33
2,00mm	3000mm	9,98
1,55mm GV	2300mm	6,23
2,05mm GV	2300mm	8,00
2,05mm GV	2500mm	8,65
2,05mm GV	3000mm	10,28
2,70mm GV	3000mm	13,54



Dica

Os trilhos para coluna de elevação são fabricados com medidas exatas, em comprimentos de até 6 metros. Consulte-nos!

Batentes e perfis diversos

T138 - Batente

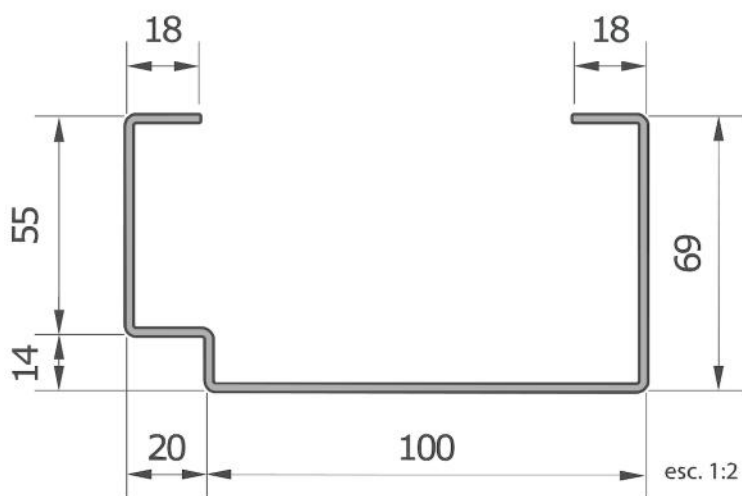

CH	COMP.	PESO kg
1,20mm	3000mm	8,34

T139 - Batente amassado para portão

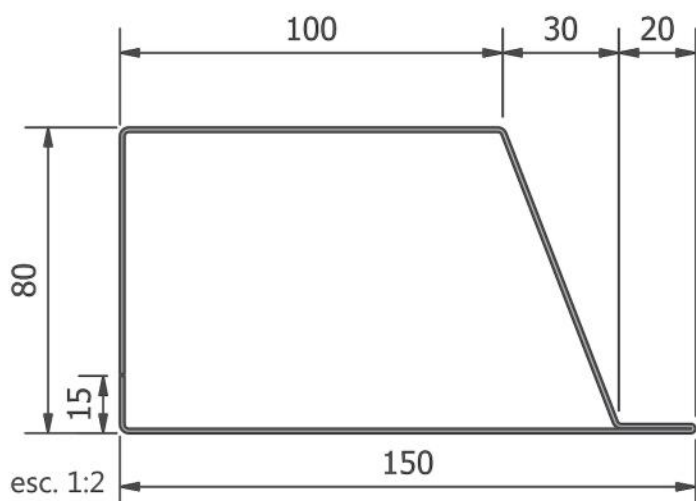

CH	COMP.	PESO kg
1,20mm	3000mm	12,60
1,50mm	3000mm	15,60
1,25mm GV	3000mm	13,00
1,55mm GV	3000mm	16,13

T193 - Batente superior para porta basculante

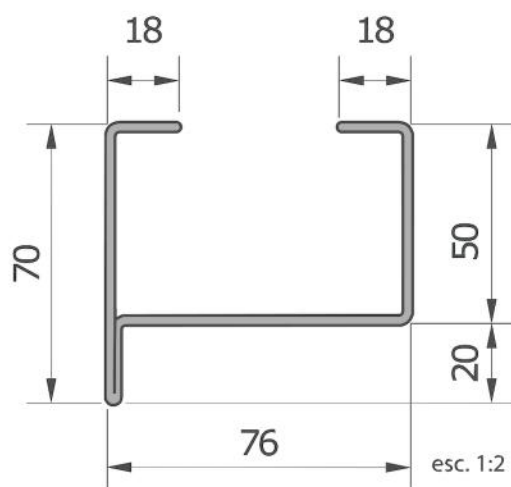

CH	COMP.	PESO kg
1,50mm	3000mm	9,00

DICA

Além dos batentes com medidas padrões, fabricamos conforme sua necessidade. Consulte-nos!



Formas e perfis diversos

- Forma para viga de laje
- Forma para Palanque
- Perfis diversos
- Calandras
- Plasma

FAMÍLIA DE FORMAS E PERFIS DIVERSOS

Fabricamos as peças para montagem das formas de laje e perfis diversos nas mais variadas espessuras e comprimentos.

Referência em exatidão nas dobras, a Tévere mantém um rigoroso controle de qualidade também na matéria-prima adquirida a fim de atender os requisitos necessários.

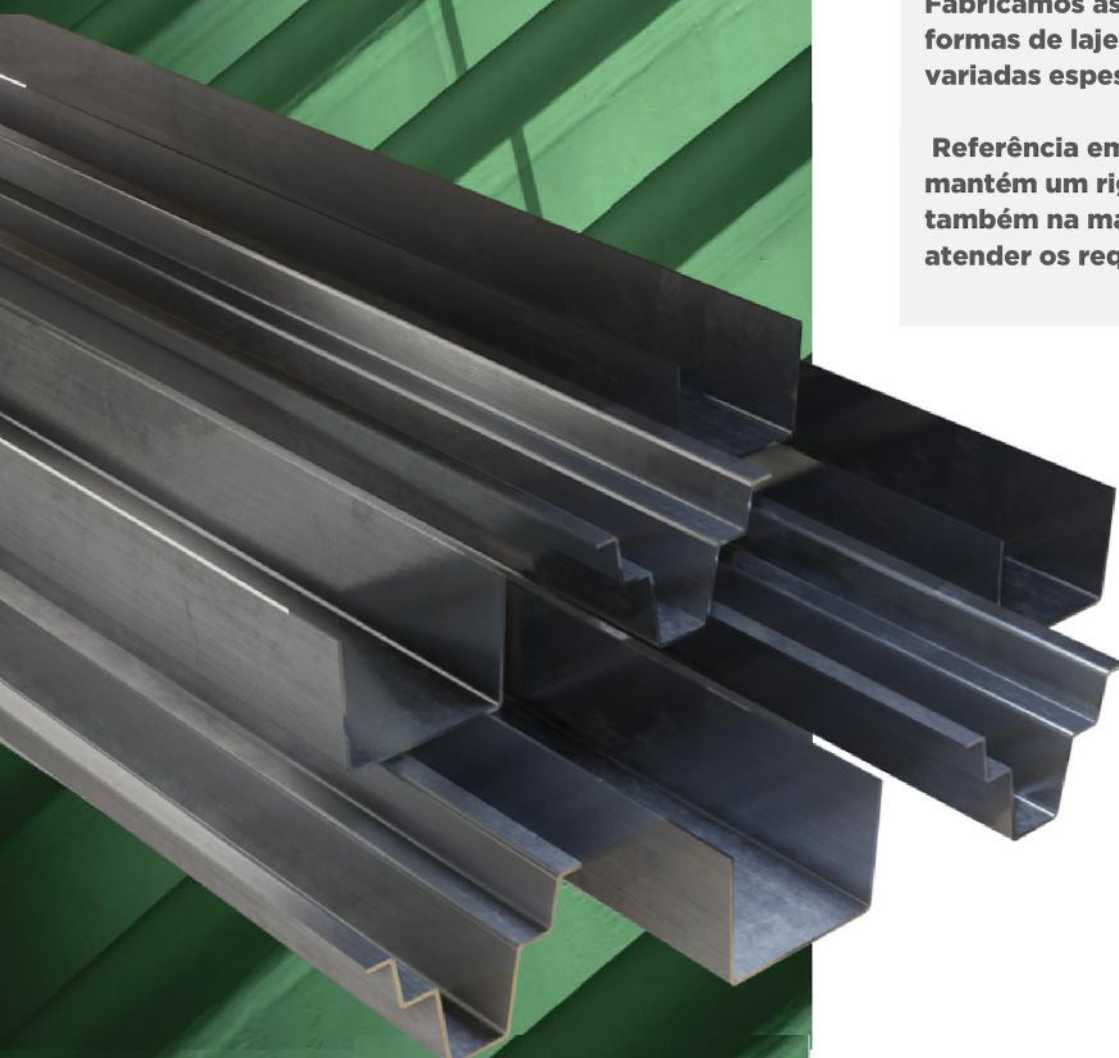

Forma para viga de laje

T112 - Forma para viga

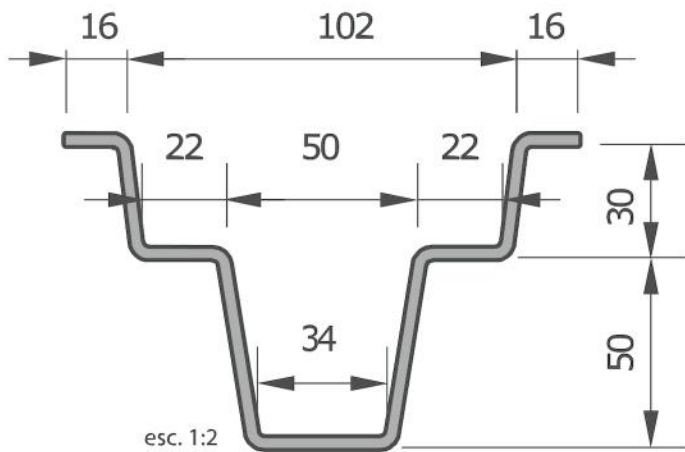

CH	COMP.	PESO kg
2,25mm	3000mm	13,68

Forma para Palanque

T188 - Forma para palanque

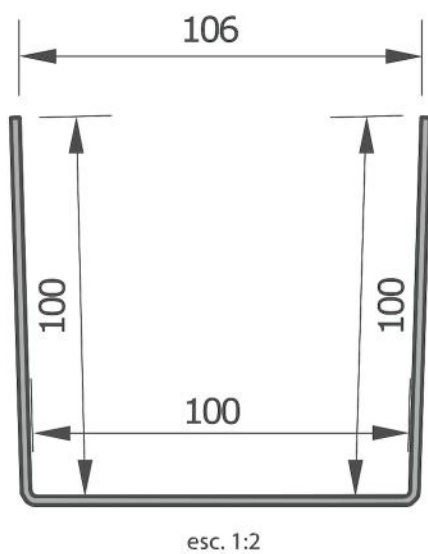

CH	COMP.	PESO kg
2,65mm	3000mm	18,86

Perfis diversos

T187 - Batente

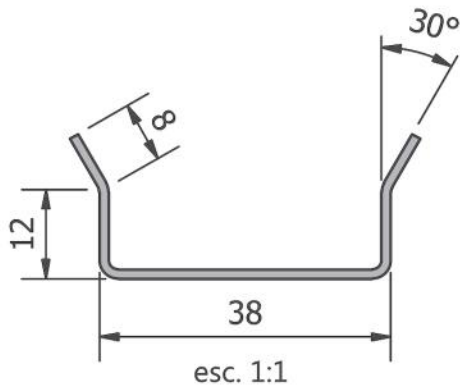

CH	COMP.	PESO kg
1,20mm	3000mm	2,07
1,50mm	3000mm	2,55

T142 - Perfil cartola

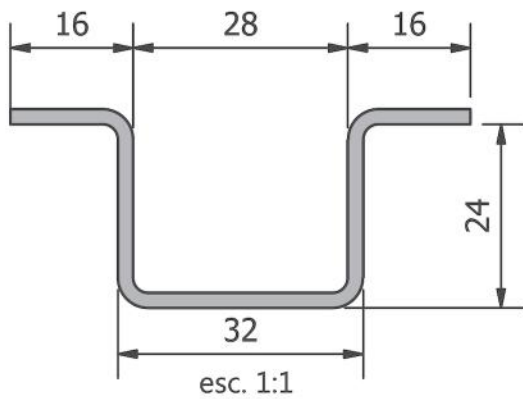

CH	COMP.	PESO kg
2,00mm	3000mm	4,90

T158 - Perfil escorregador

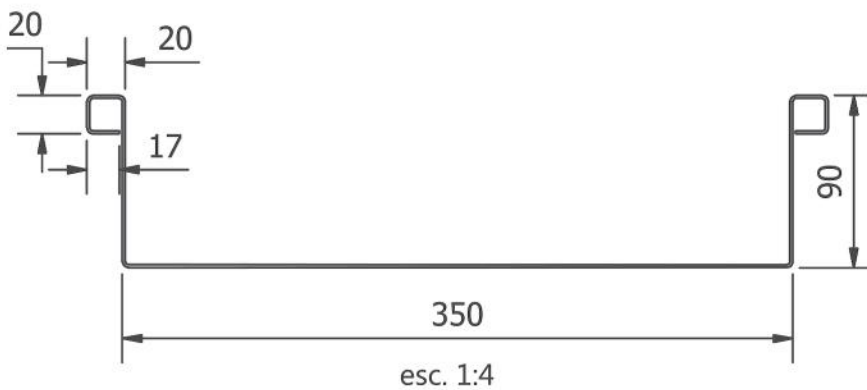

CH	COMP.	PESO kg
1,50mm	3000mm	22,10
1,55mm GV	3000mm	22,80

Calandra para chapas lisas

Calandra 01

Possui rolos com 100mm de diâmetro para peças com comprimento máximo de 2000mm

Sobre a fabricação:

Espessura mínima de 0,80mm / Espessura máxima de 4,75mm.

Diâmetro mínimo possível para a fabricação é de 170mm e peças com comprimento de até 1500mm, para espessuras de:

• 1,20mm • 1,50mm • 2,00mm • 2,25mm • 2,65mm

Calandra 02

Possui rolos com 200mm de diâmetro para peças com comprimento máximo de 3000mm

Sobre a fabricação:

Espessura mínima de 1,20mm / Espessura máxima de 6,30mm.

Diâmetro mínimo possível para a fabricação é de 270mm e peças com comprimento de até 3000mm.



Sugestão de cálculo calandra:
 $170 \text{ mm} \times 3.1416 \text{ PI} = 535 \text{ mm corte}$
 $535 \text{ mm} / 3.1416 \text{ PI} = 170 \text{ de diâmetro}$

Plasma



DICA

Corte PLASMA realizado em máquina CNC de alta performance com plasma de alta resolução que permite cortes rápidos e precisos em chapas até 50,00mm em chapas Fina Frio, Fina Quente e Galvanizada. Solicite seu orçamento!



Degraus e calhas de posto

- **Degraus diversos**
- **Calhas**

FAMÍLIA DEGRAUS E CALHAS DE POSTO

A Tévere fabrica degraus em chapas lisas e antiderrapantes, com ampla variedade de bitolas que podem ser utilizadas

nos mais variados setores, como: indústrias, residências, implementos agrícolas, implementos rodoviários, construções mecânicas, entre outros.

As calhas de posto servem para impedir que os efluentes originários da pista de abastecimento, troca de óleo e lavação, ultrapassem os limites dos pisos de concreto impermeável que podem causar degradação. Trabalhamos com canaletas nas medidas padrão ou sob medida nas chapas Fina Quente e Galvanizadas.

Degraus diversos

DEGRAU CARACOL - CHAPA LISA

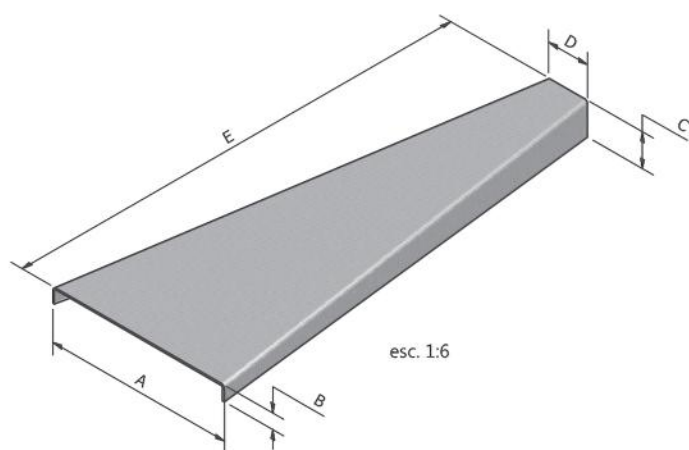

ESPESSURA	A	B	C	D	E	PESO TEÓRICO
2,00mm	300mm	25mm	60mm	70mm	550mm	2,38kg
2,25mm	300mm	25mm	60mm	70mm	550mm	2,67kg
2,65mm	300mm	25mm	60mm	70mm	550mm	3,15kg
3,00mm	300mm	25mm	60mm	70mm	550mm	3,56kg

DEGRAU CARACOL - CHAPA XADREZ (ANTIDERRAPANTE)

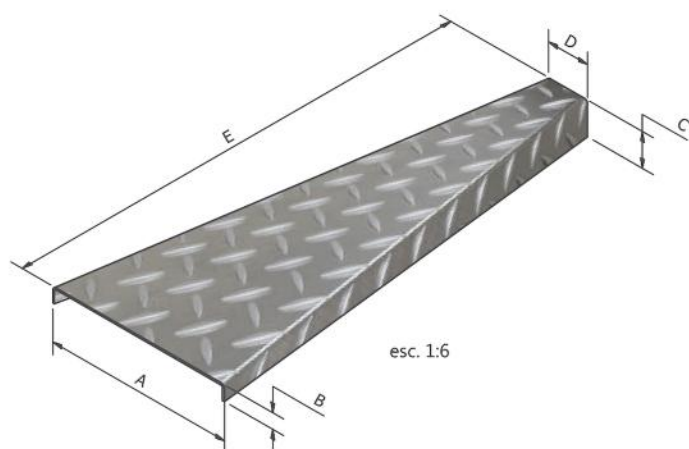

ESPESSURA	A	B	C	D	E	PESO TEÓRICO
3,00mm	300mm	25mm	56mm	70mm	550mm	3,90kg
3,00mm	300mm	25mm	56mm	70mm	600mm	4,26kg
3,00mm	300mm	25mm	56mm	70mm	750mm	5,32kg

DICA

Produzimos em chapa de alumínio Xadrez. Solicite seu orçamento.



Degraus diversos

DEGRAU RETO EM U - CHAPA LISA E XADREZ (ANTIDERRAPANTE)

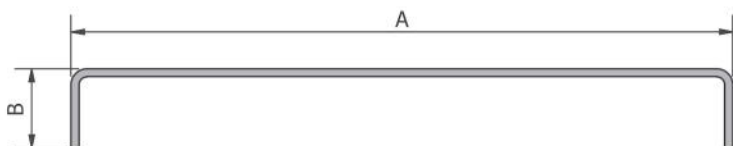

ESPESSURA	A	B	COMPRIMENTO	PESO TÉORICO
3,00mm	250mm	30mm	750mm	5,93kg
3,00mm	250mm	30mm	1000mm	7,91kg
3,00mm	250mm	30mm	1200mm	9,49kg

DEGRAU ENRIJECIDO - CHAPA LISA E XADREZ (ANTIDERRAPANTE)

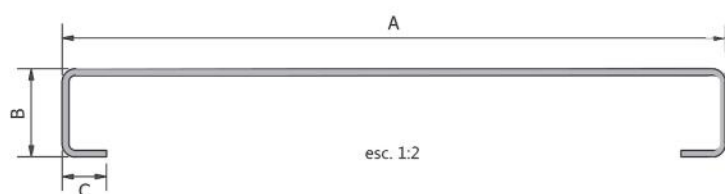

ESPESSURA	A	B	C	COMPRIMENTO	PESO TÉORICO
3,00mm	300mm	40mm	20mm	750mm	7,90kg
3,00mm	300mm	40mm	20mm	1000mm	10,50kg
3,00mm	300mm	40mm	20mm	1200mm	12,60kg

Produzimos degraus nos mais variados modelos, espessuras e comprimentos conforme necessidade do cliente.

DEGRAU SEQUENCIAL LISO



DEGRAU SEQUENCIAL XADREZ

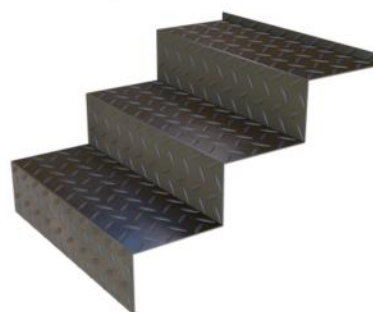

DEGRAU EM Z LISO



DEGRAU EM Z XADREZ



Calhas

Calha de posto

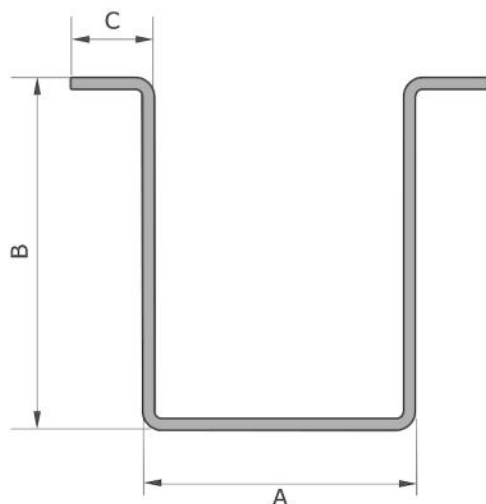

ESPESSURA	A	B	C	COMPRIMENTO	PESO TÉORICO
2,00mm	56mm	78mm	20mm	3000mm	11,33kg
2,65mm	56mm	78mm	22mm	3000mm	14,93kg

Calha posto enrijecida

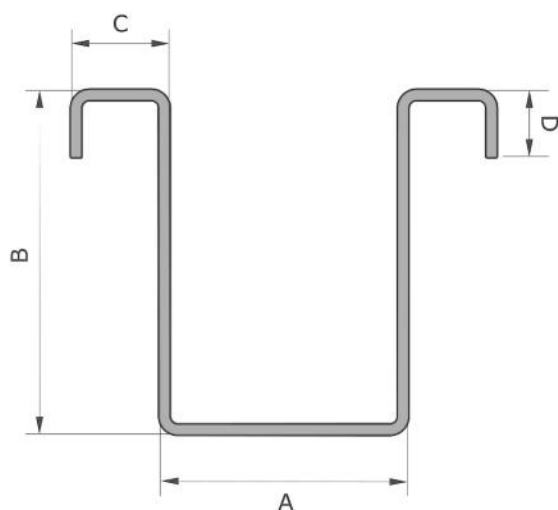

ESPESSURA	A	B	C	D	COMPRIMENTO	PESO TÉORICO
2,00mm	56mm	73mm	20mm	15mm	3000mm	11,40kg
2,65mm	56mm	75mm	21mm	15mm	3000mm	15,00kg

DICA

Utilize as chapas galvanizadas com revestimento Z275 para maior durabilidade, evitando a corrosão precoce de seu material. Consulte-nos!



Chapas

- **Chapas dobradas**
- **T96 - Chapa Frisada**
- **T80 - Chapa Onda Grega**
- **T94 - Chapa Búzio**
- **T97 - Chapa Trapezoidal**
- **T113 - Chapa Lambril**
- **Chapas lisas**

FAMÍLIA DE CHAPAS

As chapas dobradas são utilizadas para fins externos, com excelente custo benefício, podendo ser fabricadas em diversas bitolas. A Tévere conta com ampla variedade de chapas lisas, das quais podemos citar: Galvanizada, Aluzinco, Fina Frio, Fina Quente, Antiderrapante, Inox e Expandida, sendo aplicadas em uso geral.

Chapas dobradas

T96 - Chapa frisada

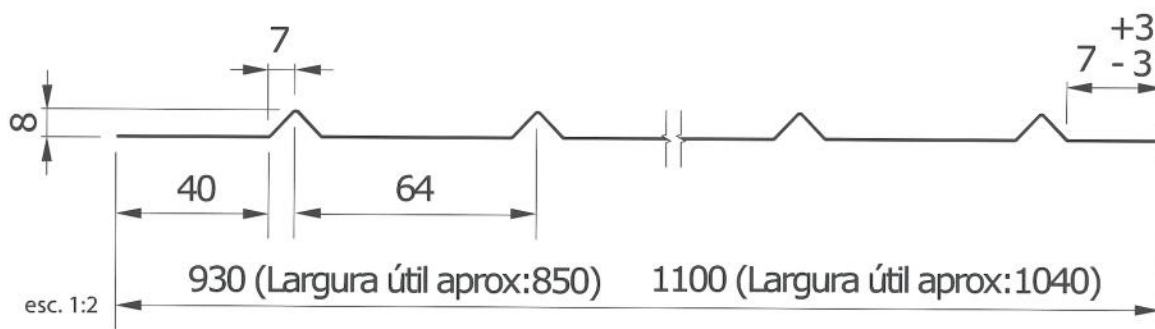

Chapa Fina fria

CH	COMP.	PESO kg
0,60mm FF	2000 x 930	9,50
0,60mm FF	2200 x 930	10,50
0,60mm FF	2500 x 930	11,90
0,60mm FF	2000 x 1110	11,40
0,60mm FF	2200 x 1110	12,60
0,60mm FF	2500 x 1110	14,30
0,75mm FF	2000 x 930	12,00
0,75mm FF	2200 x 930	13,30
0,75mm FF	2500 x 930	15,00
0,75mm FF	3000 x 930	17,70
0,75mm FF	2000 x 1110	14,40
0,75mm FF	2200 x 1110	15,80
0,75mm FF	2500 x 1110	18,00
0,75mm FF	3000 x 1110	21,60
0,90mm FF	2000 x 930	14,40
0,90mm FF	2200 x 930	15,70
0,90mm FF	2500 x 930	17,80
0,90mm FF	3000 x 930	21,60
0,90mm FF	2000 x 1110	17,00
0,90mm FF	2200 x 1110	19,00
0,90mm FF	2500 x 1110	21,60
0,90mm FF	3000 x 1110	25,90

Chapa Galvanizada

CH	COMP.	PESO kg
0,43mmGV	2000 x 930	6,62
0,43mmGV	2200 x 930	7,28
0,43mmGV	2500 x 930	8,28
0,43mmGV	3000 x 930	9,93
0,43mmGV	2000 x 1110	7,94
0,43mmGV	2200 x 1110	8,73
0,43mmGV	2500 x 1110	9,93
0,43mmGV	3000 x 1110	11,91
0,50mmGV	2000 x 930	7,50
0,50mmGV	2200 x 930	8,25
0,50mmGV	2500 x 930	9,38
0,50mmGV	3000 x 930	11,25
0,50mm GV	2000 x 1110	9,00
0,50mm GV	2200 x 1110	9,90
0,50mm GV	2500 x 1110	11,25
0,50mm GV	3000 x 1110	13,50
0,65mmGV	2000 x 930	10,02
0,65mmGV	2200 x 930	11,02
0,65mmGV	2500 x 930	12,52
0,65mmGV	3000 x 930	15,03
0,65mm GV	2000 x 1110	12,02
0,65mm GV	2200 x 1110	13,22
0,65mm GV	2500 x 1110	15,03
0,65mm GV	3000 x 1110	18,03

Chapa Galvanizada

CH	COMP.	PESO kg
0,80mmGV	2000 x 930	12,70
0,80mmGV	2200 x 930	14,08
0,80mmGV	2500 x 930	15,70
0,80mmGV	3000 x 930	19,20
0,80mmGV	2000 x 1110	15,10
0,80mmGV	2200 x 1110	16,60
0,80mmGV	2500 x 1110	18,90
0,95mmGV	2000 x 930	15,20
0,95mmGV	2200 x 930	16,40
0,95mmGV	2500 x 930	18,64
0,95mmGV	2000 x 1110	17,90
0,95mmGV	2200 x 1110	19,68
0,95mmGV	2500 x 1110	23,37
0,95mmGV	3000 x 1110	27,00

Chapa Aluzinco

CH	COMP.	PESO kg
0,43mmAZ	2000 x 1110	7,46
0,43mmAZ	2200 x 1110	8,21
0,43mmAZ	2500 x 1110	9,33
0,43mmAZ	3000 x 1110	11,19
0,50mm AZ	2000 x 1110	8,82
0,50mm AZ	2200 x 1110	9,70
0,50mm AZ	2500 x 1110	11,03
0,50mm AZ	3000 x 1110	13,23

DICA

Além das chapas frisadas serem usadas para fechamento de portas e portões, podem ser utilizadas para platibandas, por ser um material de fácil instalação.



Chapas dobradas

T180 - Chapa onda Grega

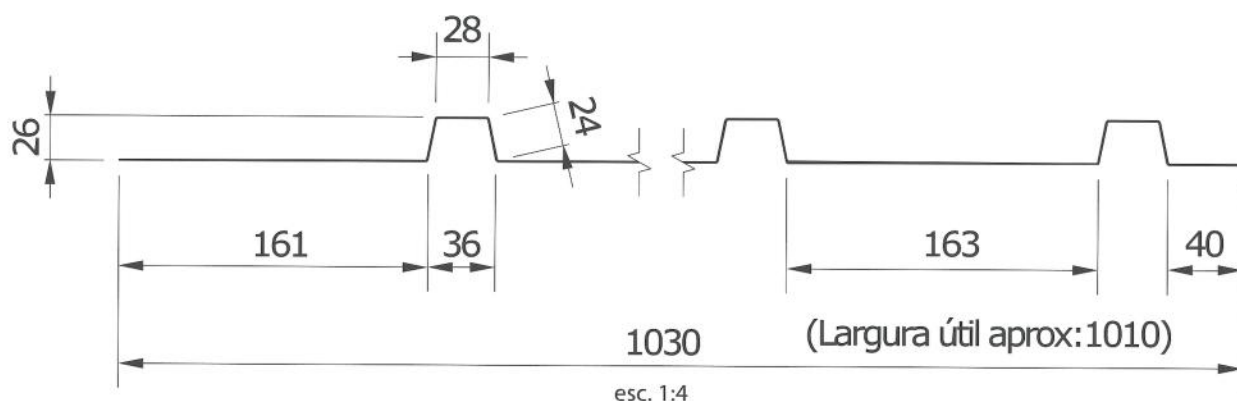

CH	COMP.	PESO kg
0,90mm FF	2000 x 1030	17,20
0,90mm FF	2200 x 1030	18,80
0,90mm FF	2500 x 1030	21,50
0,90mm FF	3000 x 1030	25,50



T194 - Chapa Búzio

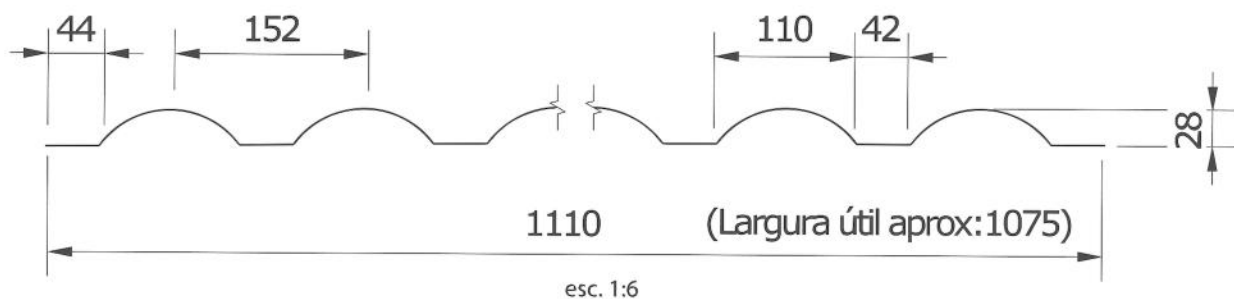

CH	COMP.	PESO kg
0,75mm FF	2000 x 1090	14,40
0,75mm FF	2200 x 1090	15,70
0,75mm FF	2500 x 1090	17,80
0,75mm FF	3000 x 1090	21,20

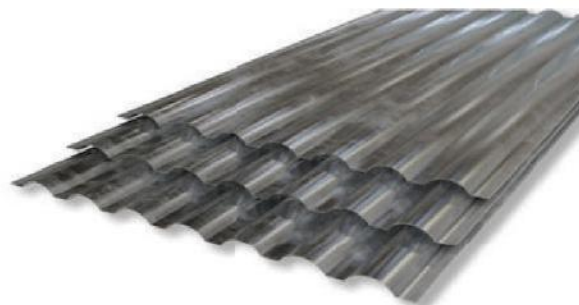

DICA

A chapa buzio é excelente para quem procura um ótimo acabamento para portões de casas, portões de elevação, portas e painéis, devido sua grande resistência ao clima adverso oferecido pelo ambiente.



Chapas dobradas

T97 - Chapa trapezoidal

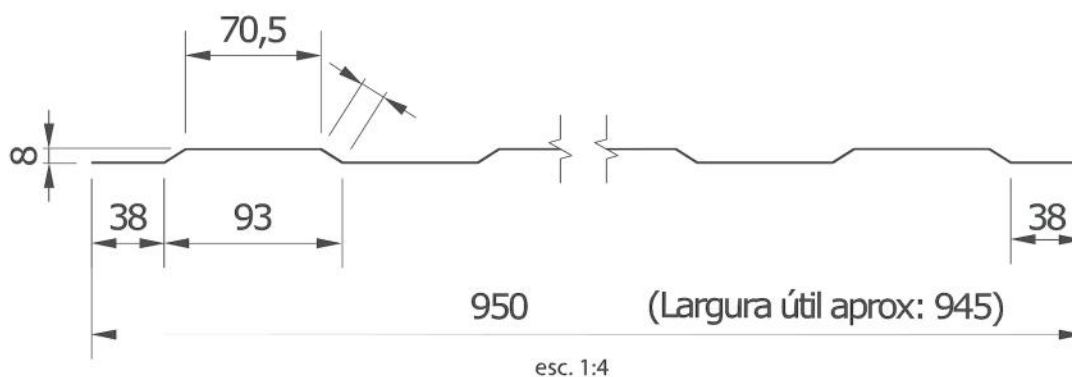

CH	COMP.	PESO kg	CH	COMP.	PESO kg
0,75mm FF	2000 x 950	12,00	0,90mm FF	2000 x 950	14,40
0,75mm FF	2200 x 950	13,30	0,90mm FF	2200 x 950	15,70
0,75mm FF	2500 x 950	15,00	0,90mm FF	2500 x 950	17,80
0,75mm FF	3000 x 950	17,70	0,90mm FF	3000 x 950	21,60



T97 - Chapa trapezoidal

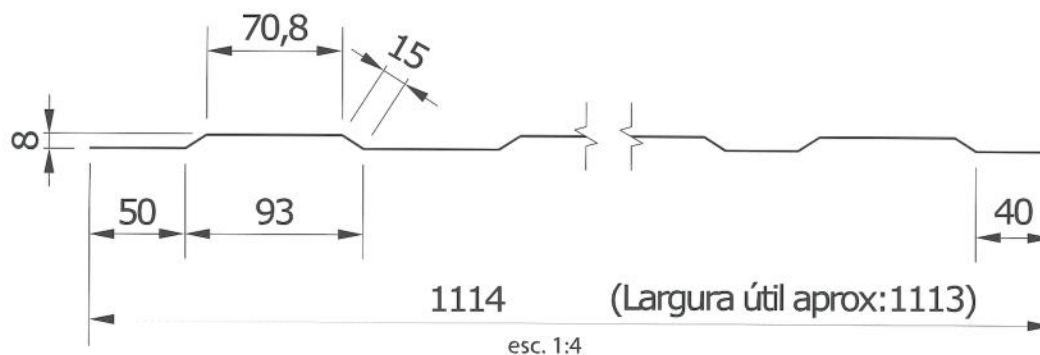

CH	COMP.	PESO kg	CH	COMP.	PESO kg
0,75mm FF	2000 x 1114	14,40	0,90mm FF	2000 x 1114	17,00
0,75mm FF	2200 x 1114	15,80	0,90mm FF	2200 x 1114	19,00
0,75mm FF	2500 x 1114	18,00	0,90mm FF	2500 x 1114	21,60
0,75mm FF	3000 x 1114	21,60	0,90mm FF	3000 x 1114	25,90

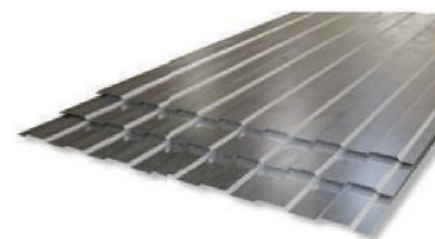

DICA

Para fixação utilize os rebites e parafusos da nossa linha de acessórios. Consulte pagina 92.



Chapas dobradas

T113 - Chapa lambril

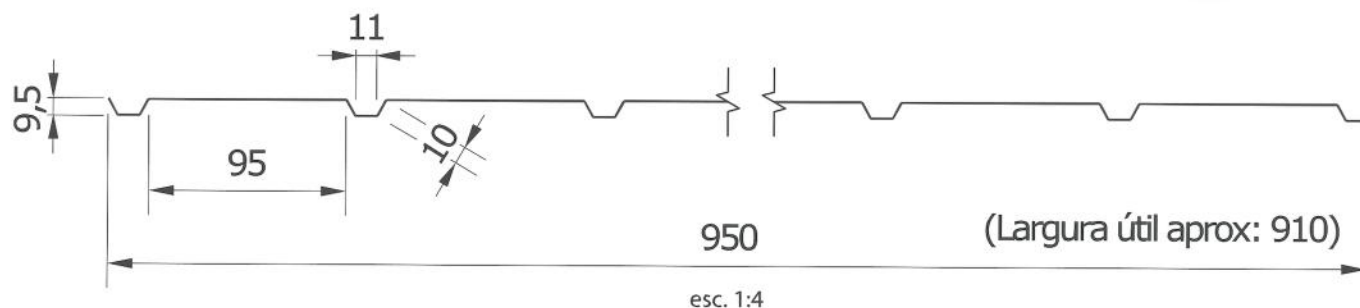

CH	COMP.	PESO kg	CH	COMP.	PESO kg	CH	COMP.	PESO kg
0,75mm FF	2000 x 950	12,00	0,90mm FF	2000 x 950	14,30	0,50mm GV	2000 x 950	7,50
0,75mm FF	2200 x 950	13,20	0,90mm FF	2200 x 950	15,70	0,50mm GV	2200 x 950	8,25
0,75mm FF	2500 x 950	15,00	0,90mm FF	2500 x 950	17,80	0,50mm GV	2500 x 950	9,38
0,75mm FF	3000 x 950	17,70	0,90mm FF	3000 x 950	21,60	0,50mm GV	3000 x 950	11,25

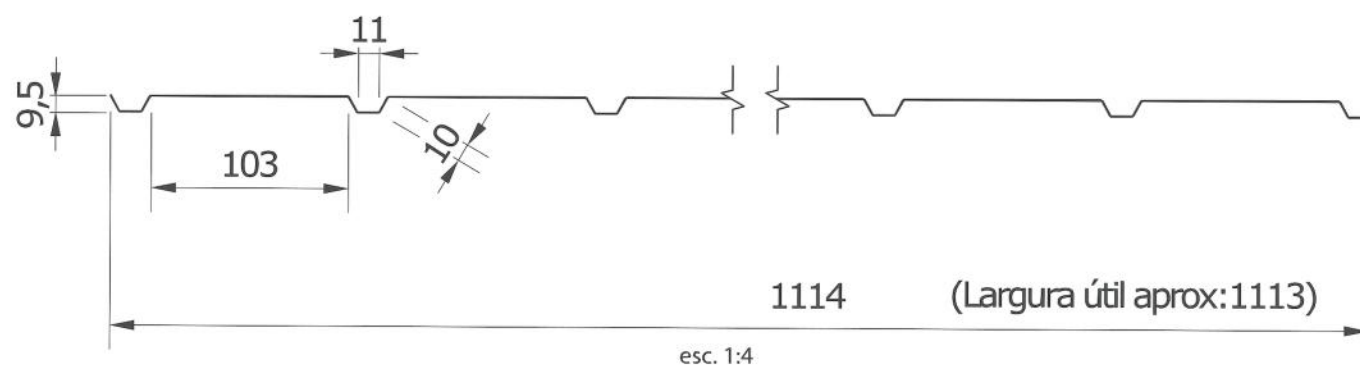

CH	COMP.	PESO kg	CH	COMP.	PESO kg	CH	COMP.	PESO kg
0,75mm FF	2000 x 1114	14,40	0,90mm FF	2000 x 1114	17,00	0,50mm GV	2000 x 1114	8,00
0,75mm FF	2200 x 1114	15,70	0,90mm FF	2200 x 1114	18,80	0,50mm GV	2200 x 1114	9,90
0,75mm FF	2500 x 1114	17,80	0,90mm FF	2500 x 1114	21,50	0,50mm GV	2500 x 1114	11,25
0,75mm FF	3000 x 1114	21,60	0,90mm FF	3000 x 1114	25,50	0,50mm GV	3000 x 1114	13,50

DICA

Para maior leveza utilize a opção de chapa lambril galvanizada.



Chapas lisas

Chapas galvanizadas



BITOLA	ESPESSURA	PESO p/m ²
30	0,35mm	2,80
28	0,43mm	3,4
26	0,50mm	4,00
24	0,65mm	5,20
22	0,80mm	6,30
20	0,95mm	7,50

BITOLA	ESPESSURA	PESO p/m ²
18	1,25mm	9,90
16	1,55mm	12,20
14	2,05mm	15,70
13	2,30mm	18,10
12	2,70mm	21,20
11	3,00mm	24,00

Dica:

Utilize as chapas galvanizadas Z275 para maior durabilidade, evitando assim a corrosão precoce de seu material. Consulte-nos!



Chapas fina a frio



BITOLA	ESPESSURA	PESO p/m ²
24	0,60mm	4,80
22	0,75mm	6,00
20	0,90mm	7,10
18	1,20mm	9,50
16	1,50mm	11,80

Chapas aluzinco

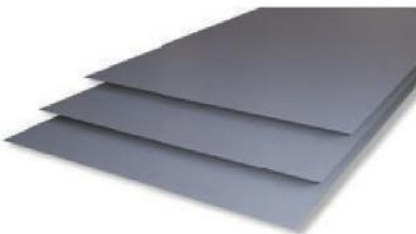

BITOLA	ESPESSURA	PESO p/m ²
28	0,43mm	3,38
26	0,50mm	3,93

Dica:

Além das medidas padrões, pode ser fornecido em tamanhos especiais. Consulte-nos!



Chapas lisas

Chapas fina a quente



BITOLA	ESPESSURA	PESO p/m ²
14	2,00mm	15,94
13	2,25mm	18,06
12	2,65mm	20,88
11	3,00mm	24,00
10	3,35mm	26,54
9	3,75mm	30,00
8	4,25mm	33,57
3/16	4,75mm	37,49
1/4	6,30mm	49,62

BITOLA	ESPESSURA	PESOp/m ²
5/16	8,00mm	64,00
3/8	9,50mm	76,00
1/2	12,50mm	102,00
5/8	16,00mm	128,00
3/4	19,00mm	152,00
1"	25,40mm	200,00
1.1/2	38,00mm	304,00
2"	50,00mm	400,00

Chapas xadrez (antiderrapante)



BITOLA	ESPESSURA	PESO p/m ²
12	2,65mm	21,67
11	3,00mm	26,69
3/16	4,75mm	40,29
1/4	6,30mm	56,36

Dica:

Além das chapas inteiras xadrez / antiderrapante, disponibilizamos a opção de corte e dobra, de acordo com sua necessidade.



Dica:

Atendemos na chapa COR nas seguintes espessuras: 2,00 à 12,70mm



Chapas lisas

Chapas inox 304



BITOLA	ESPESSURA	PESO p/m ²
28	0,40 mm	3,18
26	0,50 mm	4,08
24	0,60 mm	4,71
19	1,00 mm	8,00
18	1,20 mm	9,52
16	1,50 mm	11,86
14	2,00 mm	15,99
11	3,00 mm	24,02

Chapas inox 430



BITOLA	ESPESSURA	PESO p/m ²
28	0,40mm	3,19
26	0,50mm	3,94
24	0,60mm	4,71
19	1,00mm	7,94
18	1,20mm	9,56

Perfis I e W

- Vigas “I” laminadas
- Vigas “W” laminadas

FAMÍLIA DE PERFIS I E W

Os perfis I e W, produzidos normalmente em aço ASTM A36, possuem alta inércia e maior resistência geométrica. São ideais para aplicações que exijam mais robustez, como implementos agrícolas e rodoviários, equipamentos de transportes e chassis diversos, vigamentos, escoramentos, guias, estrutura de sustentação, entre outras.

Vigas "I" laminadas

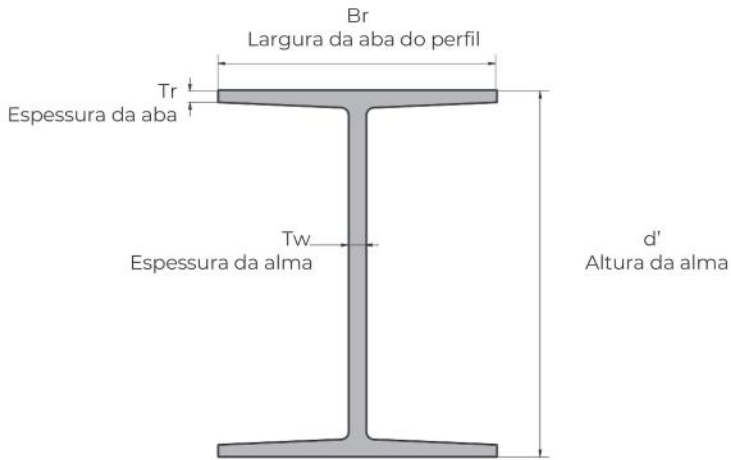

Dica:

Utilize as vigas I para ganhos de produtividade no processo de fabricação das estruturas.



Viga I cód. 0001

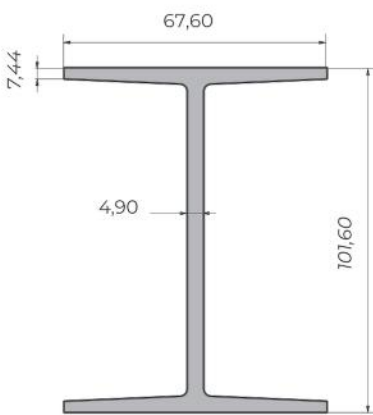

Des.	d	Br	Tr	Tw	PESO kg
1ª Alma	101,60	67,60	7,44	4,90	70,70

Viga I cód. 1948

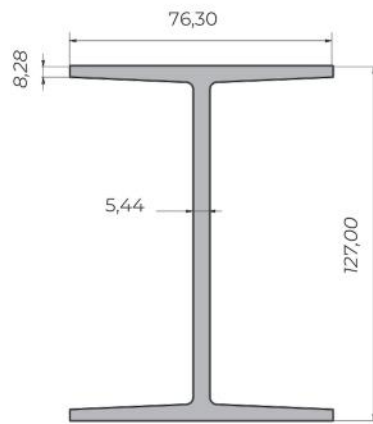

Des.	d	Br	Tr	Tw	PESO kg
1ª Alma	127,00	76,30	8,28	5,44	90,00

Viga I cód. 1949

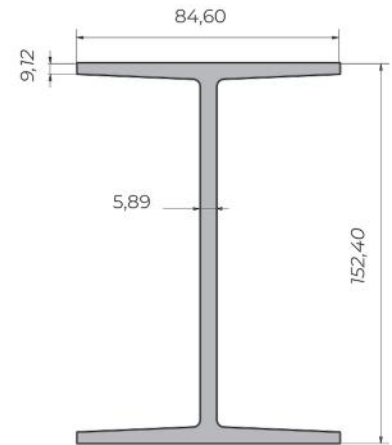

Des.	d	Br	Tr	Tw	PESO kg
1ª Alma	152,40	84,60	9,12	5,89	112,00

Viga I cód. 3687

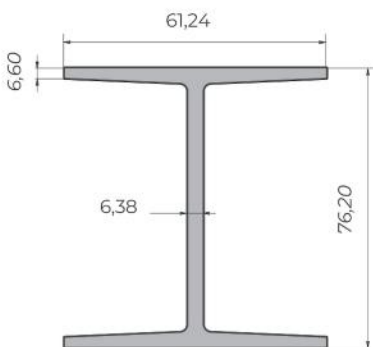

Des.	d	Br	Tr	Tw	PESO kg
2ª Alma	76,20	61,24	6,60	6,38	58,08

Viga I cód. 2134

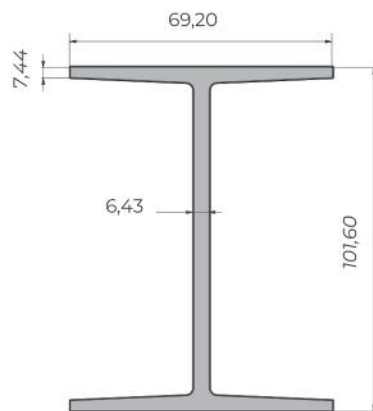

Des.	d	Br	Tr	Tw	PESO kg
2ª Alma	101,60	69,20	7,44	6,43	79,56

Viga I cód. 2997

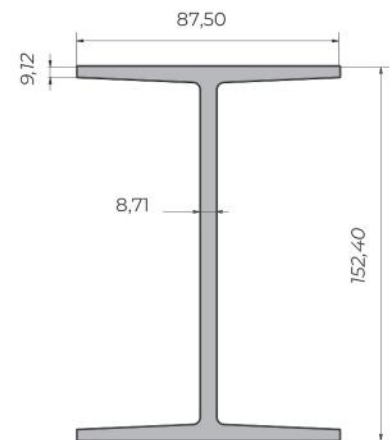

Des.	d	Br	Tr	Tw	PESO kg
2ª Alma	152,40	87,50	9,12	8,71	132,00

Vigas "W" laminadas

Viga W cód. 2507

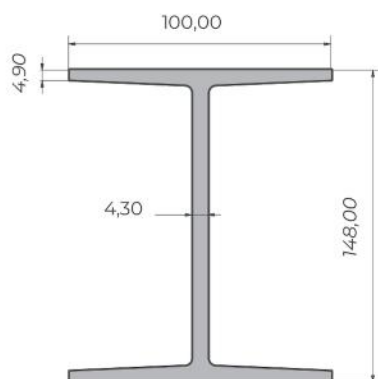

Bitola mm x kg/m	d	Br	Tr	Tw	PESO kg
W 150 x 13	148,00	100,00	4,90	4,30	78,00

Viga W cód. 2206

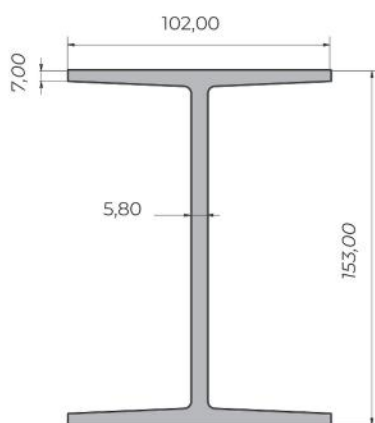

Bitola mm x kg/m	d	Br	Tr	Tw	PESO kg
W 150 x 18	153,00	102,00	7,00	5,80	107,00

Viga W cód. 2165

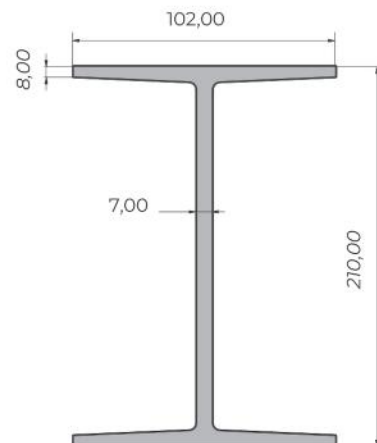

Bitola mm x kg/m	d	Br	Tr	Tw	PESO kg
W 200 x 22,50	210,00	102,00	8,00	7,00	135,00

Viga W cód. 3314

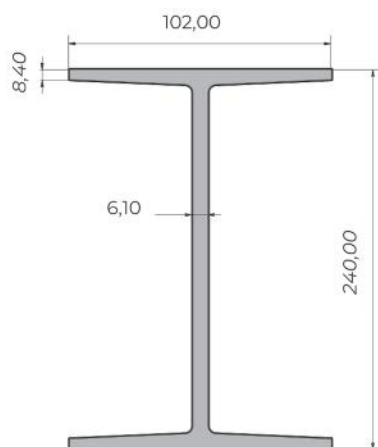

Bitola mm x kg/m	d	Br	Tr	Tw	PESO kg
W 250 x 25,30	240,00	102,00	8,40	6,10	151,80

Viga W cód. 2166

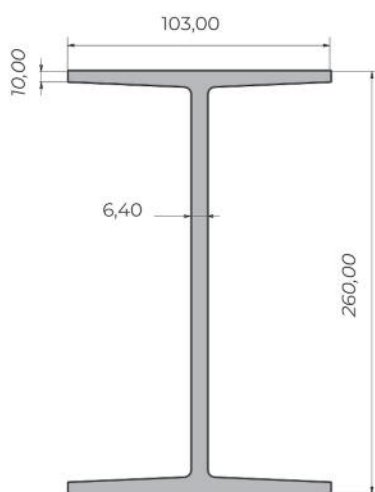

Bitola mm x kg/m	d	Br	Tr	Tw	PESO kg
W 250 x 28,40	260,00	103,00	10,00	6,40	170,40

Viga W cód. 2205

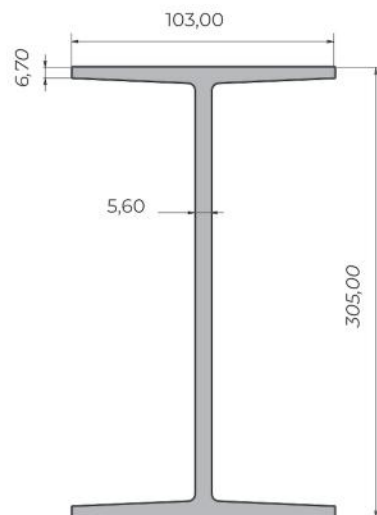

Bitola mm x kg/m	d	Br	Tr	Tw	PESO kg
W 310 x 23,80	305,00	103,00	6,70	5,60	143,00

DICA

Este produto é extremamente versátil sendo suas principais aplicações em máquinas e equipamentos, serralheria, esquadrias, implementos agrícolas, estruturas metálicas em geral.



Vigas "W" laminadas

Viga W cód. 2968

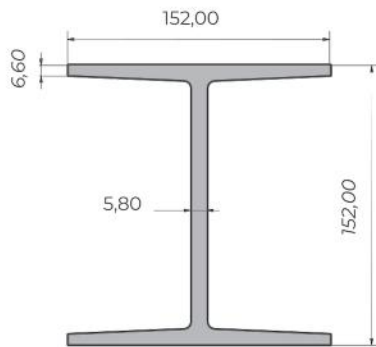

Bitola mm x kg/m	d	Br	Tr	Tw	PESO kg
WH 150 x 22,50	152,00	152,00	6,60	5,80	135,00

Viga W cód. 2969

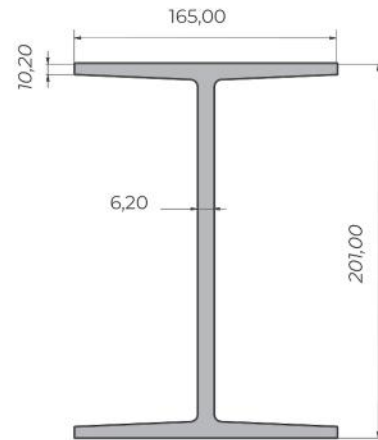

Bitola mm x kg/m	d	Br	Tr	Tw	PESO kg
WH 200 x 35,90	201,00	165,00	10,20	6,20	215,40

Viga W cód. 2313

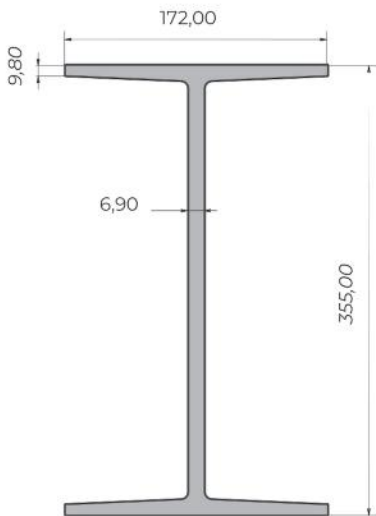

Bitola mm x kg/m	d	Br	Tr	Tw	PESO kg
WH 360 x 44,00	355,00	172,00	9,80	6,90	264,00

Viga W cód. 2314

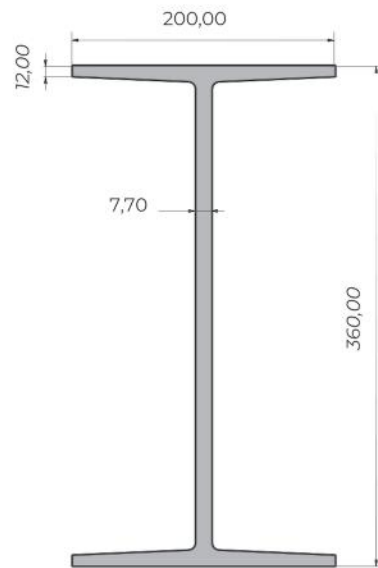

Bitola mm x kg/m	d	Br	Tr	Tw	PESO kg
WH 360 x 64,00	360,00	200	12,00	7,70	384,00



Dica

Disponibilizamos as vigas W em perfis de até 12 metros.



Laminados

- Ferro chato laminado c/ 6 metros
- Cantoneiras laminadas c/ 6 metros
- Ferro tôle laminado c/ 6 metros
- Ferro quadrado mecânico c/ 6 metros
- Ferro redondo mecânico
- Barra redonda trefilada 1020
- Barra redonda trefilada 1045
- Laminado ferro tribar
- Laminado ferro estrela

LAMINADOS

Os perfis laminados têm formas diferentes para se adequar às necessidades de cada estrutura, apresentam praticamente as mesmas aplicações, sendo algumas mais específicas. A Tévere oferece a melhor e mais completa linha de perfis laminados, que possuem especificações técnicas adequadas a cada aplicação, trazendo a melhor performance, garantia, produtividade e qualidade para o seu negócio.

Laminados

FERRO CHATO LAMINADO Cl 6m



ESPESSURA	PESO PÇ
3/4x3	68,40kg
3/4x2	45,60kg
5/8x3	57,00kg
5/8x2	38,00kg
1x3	91,15kg
1/2x4	61,00kg
1/2x3	45,00kg
1/2x2.1/2	37,70kg
1/2x2	39,90kg
1/2x1.1/2	22,80kg
1/2x1.1/4	19,02kg
3/8x4	46,00kg
3/8x3	34,50kg
3/8x2.1/2	28,80kg
3/8x2	22,80kg
3/8x1.1/2	17,40kg
3/8x1.1/4	14,50kg
3/8x1	11,60kg
5/16x3	28,60kg
5/16x2.1/2	23,50kg
5/16x2	18,40kg
5/16x1.1/2	14,30kg
5/16x1.1/4	11,80kg
5/16x1	9,48kg
1/4x4	30,60kg
1/4x3	22,80kg
1/4x2.1/2	19,50kg
1/4x2	15,50kg
1/4x1.1/2	11,50kg
1/4x1.1/4	9,50kg
1/4x1	7,60kg
1/4x3/4	5,30kg
1/4x5/8	4,34kg
1/4x1/2	3,50kg

ESPESSURA	PESO PÇ
3/16x2	11,60kg
3/16x1.1/2	8,60kg
3/16x1.1/4	6,90kg
3/16x1	5,35kg
3/16x7/8	4,75kg
3/16x3/4	3,95kg
3/16x5/8	3,30kg
3/16x1/2	2,55kg
1/8x2	7,80kg
1/8x1.1/2	5,80kg
1/8x1.1/4	4,80kg
1/8x1	3,44kg
1/8x7/8	2,98kg
1/8x3/4	2,70kg
1/8x5/8	2,11kg
1/8x1/2	1,68kg
1/8x3/8	1,30kg
serr 5/8	1,95kg
serr 1/2	1,54kg



DICA

Principais aplicações:

- Serralheria
- Esquadrias
- Estruturas Metálicas
- Máquinas e equipamentos
- Indústria Mecânica em geral

Laminados

Cantoneiras laminadas cl 6m



ESPESSURA	PESO PÇ
3/8x2.1/2	52,46kg
3/8x2	42,00kg
5/16x4	72,50kg
5/16x3	53,60kg
5/16x2	34,92kg
1/4x4	60,00kg
1/4x3	43,74kg
1/4x2.1/2	36,00kg
1/4x2	29,00kg
1/4x1.1/2	20,50kg
1/4x1.1/4	17,50kg

ESPESSURA	PESO PÇ
1/4x1	13,54kg
3/16x3	33,12kg
3/16x2.1/2	28,00kg
3/16x2	22,50kg
3/16x1.1/2	16,00kg
3/16x1.1/4	13,17kg
3/16x1	9,90kg
1/8x2	14,80kg
1/8x1.1/2	11,35kg
1/8x1.1/4	8,90kg

Ferro tôle laminado cl 6m

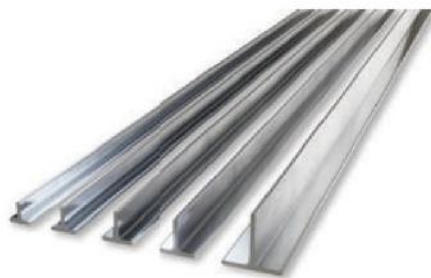

ESPESSURA	PESO PÇ
1/8x1.1/2	11,60kg
1/8x1	7,50kg
1/8x7/8	6,30kg
1/8x3/4	5,20kg
1/8x5/8	4,30kg
Serr 3/4	4,30kg

Ferro quadrado mecânico cl 6m



ESPESSURA	PESO PÇ
5/16	3,00kg
3/8	4,16kg
1/2	7,55kg
5/8	12,00kg
2"	121,56kg

Ferro redondo mecânico



ESPESSURA	PESO PÇ
Mec 1/4" 6m	1,48kg
Mec 5/16" 6m	2,31kg
Mec 3/8" 6m	3,35kg
Mec 1/2" Serr 6m	5,40kg
Mec 1/2" 6m	6,00kg
Mec 5/8" 6m	9,50kg
Mec 3/4" 6m	13,60kg
Mec 7/8" 6m	18,30kg
Mec 1" 6m	24,40kg

ESPESSURA	PESO PÇ
Mec 1.1/4" A-36 1m	6,33kg
Mec 1.1/4" 1020 1 m	6,22kg
Mec 2" 1020 1m	16,19kg
Mec 2.1/2" 1020 1m	25,28kg
Mec 3" A-36 1m	36,39kg
Mec 4" 1020 1m	63,46kg

Laminados

Barra redonda trefilada 1020



ESPESSURA	PESO PÇ
Tref 1020 04,76mm 6m	0,90kg
Tref 1020 12,70mm 6m	6,00kg
Tref 1020 15,88mm 6m	9,33kg
Tref 1020 16,00mm 6m	9,50kg
Tref 1020 19,05mm 6m	13,42kg
Tref 1020 22,22mm 6m	18,26kg
Tref 1020 25,00mm 6m	23,20kg
Tref 1020 25,40mm 6m	23,86kg
Tref 1020 28,00mm 6m	31,75kg

ESPESSURA	PESO PÇ
Tref 1020 30,00mm 1m	5,55kg
Tref 1020 32,00mm 1m	6,32kg
Tref 1020 50,00mm 1m	15,92kg

Barra redonda trefilada 1045



ESPESSURA	PESO PÇ
Tref 1045 4,76mm 6m	0,90kg
Tref 1045 12,70mm 6m	6,00kg
Tref 1045 15,88mm 6m	9,33kg
Tref 1045 16,00mm 6m	9,50kg
Tref 1045 19,05mm 6m	13,42kg
Tref 1045 20,00mm 6m	14,80kg
Tref 1045 22,22mm 6m	18,26kg
Tref 1045 25,00mm 6m	23,86kg

ESPESSURA	PESO PÇ
Tref 1045 30,00mm 1m	5,60kg
Tref 1045 35,00mm 1m	7,60 kg
Tref 1045 38,00mm 1m	8,95 kg
Tref 1045 40,00mm 1m	10,00kg
Tref 1045 42,00mm 1m	10,90kg
Tref 1045 45,00mm 1m	12,70kg
Tref 1045 50,00mm 1m	15,92kg
Tref 1045 55,00mm 1m	18,65kg
Tref 1045 60,00mm 1m	22,20kg
Tref 1045 65,00mm 1m	26,00kg

Ferro tribar



Descrição	COMP	PESO PÇ
10mm	6m	3,10kg

Ferro estrela

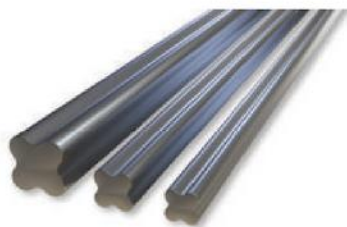

Descrição	COMP	PESO PÇ
1/2	6m	5,50kg
3/8	6m	4,30kg
10,50	6m	4,27kg

DICA

A barra redonda trefilada é utilizada em diversas aplicações como: implementos agrícolas, autopeças, máquinas e equipamentos.



Telas e chapa expandida

- Telas
- Chapa expandida

FAMÍLIA DE TELAS E CHAPA EXPANDIDA

Os produtos Tévere destacam- se pela qualidade e diversidade, pois dispomos de telas e chapa expandida para melhor atender nosso cliente, visando sua satisfação e facilidade na aplicação.

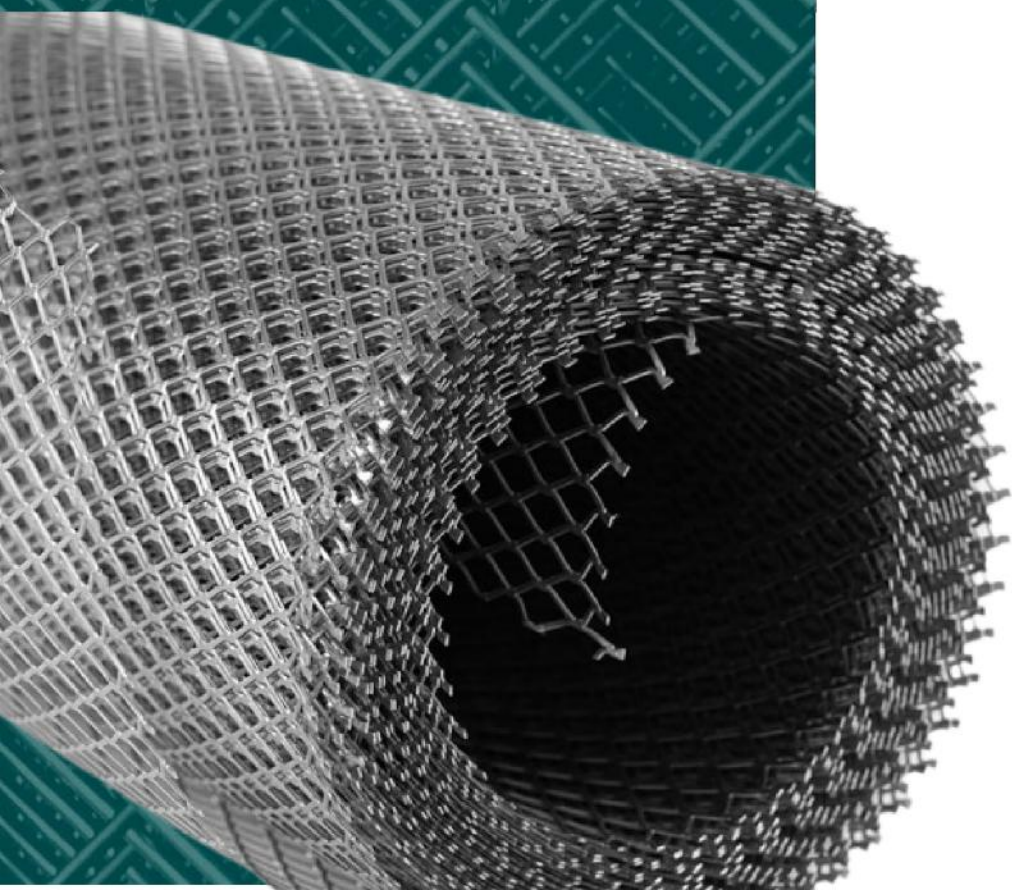

Telas e Chapa Expandida

Telas soldadas*

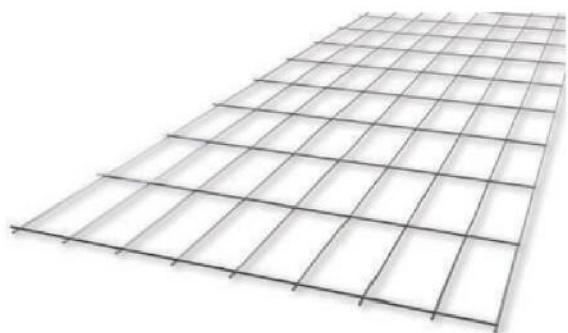

Descrição	Altura	Malha	Fio
Tela soldada Insul	1,00m	150x50mm	2,30
Tela soldada Insul	1,20m	150x50mm	2,30
Tela soldada Insul	1,50m	150x50mm	2,30
Tela soldada Insul	1,80m	150x50mm	2,30
Tela soldada Insul	2,00m	150x50mm	2,30

*Rolos de 25 metros

Chapas Expandidas

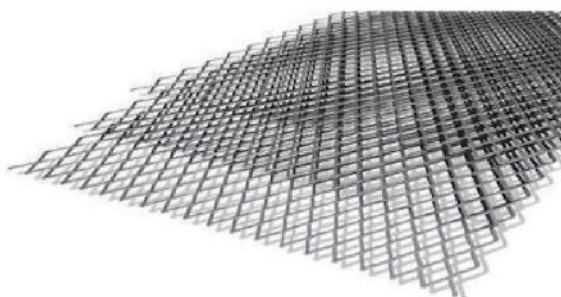

MEDIDAS	ESPESSURA	COMP.	PESO p/pç
20x50	3,00mm	1000x2000	11,80
20x50	3,00mm	1000x3000	17,60
20x50	3,00mm	1200x2000	12,40
20x50	3,00mm	1200x3000	23,70
50x100	4,75mm	1200x2000	12,40
50x100	4,75mm	1200x3000	19,50
50x100	6,30mm	1200x2000	20,20
50x100	6,30mm	1200x3000	30,00

Rolo de chapa expandida**

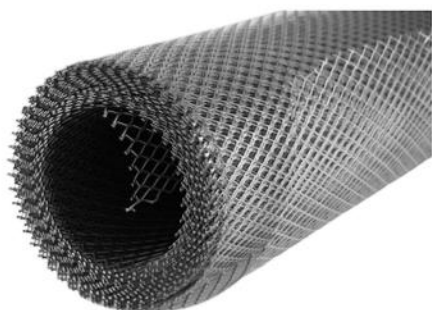

Descrição	Altura	Malha	Fio
Rolo EXP	1,00m	12x25mm	1,20
Rolo EXP	1,20m	12x25mm	1,20

**Rolos de 10 metros

DICA

As telas possuem o melhor custo benefício do mercado. Solicite seu orçamento!



Tubos industriais



- Tubo ind. red. preto c/ 6 m
- Tubo ind. red. galv. sem rosca met. c/ 6 m
- Tubo ind. red. galv. com rosca c/ 6 m
- Tubo ind. ret. preto c/ 6 m
- Tubo ind. quad. preto c/ 6 m
- Tubo ind. oblongo preto c/ 6 m
- Tubo ind. quad. galv. metalizado c/ 6 m
- Tubo ind. ret. galv. metalizado c/ 6 m

FAMÍLIA TUBOS INDUSTRIAIS

Os tubos industriais possuem vários formatos, a escolha do mais adequado é realizada de acordo com a finalidade de seu projeto: serralherias, estruturas metálicas, grades, construção civil, corrimões, entre outros.

A Tévere fornece no formato quadrado, retangular, redondo e oblongo, em variadas bitolas e materiais, Fina Frio, Fina Quente e Galvanizados (com rosca e sem rosca) para atender toda a demanda do mercado sendo referência no segmento e especialista na distribuição dos produtos.

Tubos industriais redondos

Tubo redondo preto cl 6 metros



Descrição	PESO PÇ
16mm x 0,90mm (5/8" externa)	2,00kg
16mm x 1,06mm (5/8" externa)	2,35kg
16mm x 1,20mm (5/8" externa)	2,70kg
16mm x 1,50mm (5/8" externa)	3,30kg
19mm x 0,90mm (3/4" externa)	2,55kg
19mm x 1,50mm (3/4" externa)	4,02kg
19mm x 1,06mm (3/4" externa)	2,95kg
19mm x 1,20mm (3/4" externa)	3,33kg
22mm x 0,90mm (7/8" externa)	2,95kg
22mm x 1,20mm (7/8" externa)	3,90kg
22mm x 1,50mm (7/8" externa)	4,60kg
22mm x 1,06mm (7/8" externa)	3,32kg
25mm x 0,90mm (1" externa)	3,30kg
25mm x 1,06mm (1" externa)	3,90kg
25mm x 1,20mm (1" externa)	4,50kg
25mm x 1,50mm (1" externa)	5,40kg
25mm x 2,00mm (1" externa)	7,30kg
25mm x 2,65mm (1" externa)	9,50kg
32mm x 0,90mm (1.1/4" externa)	4,30kg
32mm x 1,06mm (1.1/4" externa)	5,00kg
32mm x 1,20mm (1.1/4" externa)	5,50kg
32mm x 1,50mm (1.1/4" externa)	6,80kg
32mm x 2,00mm (1.1/4" externa)	9,10kg
32mm x 2,65mm (1.1/4" externa)	12,00kg
32mm x 3,00mm (1.1/4" externa)	12,90kg
38mm x 0,90mm (1.1/2" externa)	5,00kg
38mm x 1,06mm (1.1/2" externa)	5,90kg
38mm x 1,20mm (1.1/2" externa)	6,89kg
38mm x 1,50mm (1.1/2" externa)	8,57kg
38mm x 2,00mm (1.1/2" externa)	11,00kg
38mm x 2,65mm (1.1/2" externa)	14,30kg
38mm x 3,00mm (1.1/2" externa)	15,80kg
44,45mmx2,25mm 6m (1.3/4 externa)	14,10kg
45mm x 2,00mm (1.3/4" externa)	12,90kg
50mm x 1,06mm (2" externa)	8,00kg
50mm x 1,20mm (2" externa)	9,00kg
50mm x 1,50mm (2" externa)	11,10kg
50mm x 2,00mm (2" externa)	14,82kg

Descrição	PESO PÇ
50mm x 2,65mm (2" externa)	19,60kg
50mm x 3,00mm (2" externa)	21,60kg
57,15mm x 2,00mm (2.1/4 externa)	17,00kg
60,30mm x 3,75mm (2.3/8 externa)	32,25kg
63mm x 1,20mm (2 1/2" externa)	11,10kg
63mm x 1,50mm (2.1/2" externa)	14,10kg
63mm x 2,00mm (2.1/2" externa)	18,80kg
63mm x 3,00mm (2.1/2" externa)	26,88kg
63,50mm x 3,75mm (2.1/2 externa)	34,00kg
75mm x 1,20mm (3" externa)	13,50kg
75mm x 1,50mm (3" externa)	17,00kg
75mm x 2,00mm (3" externa)	22,50kg
75mm x 2,65mm (3" externa)	30,00kg
75mm x 3,00mm (3" externa)	32,80kg
75 mm x 3,35mm (3" externa)	36,20kg
75mm x 4,25mm (3" externa)	45,92kg
75mm x 4,75mm (3" externa)	51,32kg
88,90mm x 3,75mm (3.1/2" externa)	49,02kg
89mm x 2,65mm (3.1/2" externa)	34,60kg
100mm x 1,50mm (4" externa)	22,50kg
100mm x 2,00mm (4" externa)	30,50kg
100mm x 2,25mm (4" externa)	34,00kg
100mm x 2,65mm (4" externa)	39,50kg
100mm x 3,00mm (4" externa)	44,60kg
100mm x 4,75mm (4" externa)	69,00kg
101,60mm x 3,75mm (4" externa)	56,26kg
127mm x 2,00mm (5" externa)	37,00kg
127mm x 2,65mm (5" externa)	49,00kg
127mm x 4,75mm (5" externa)	86,00kg



Dica

Em conformidade com as normas técnicas, os tubos redondos podem ser utilizados nos mais variados setores da indústria, construção e serralheria. Solicite seu orçamento!

Tubos industriais redondos

Tubo redondo galv. sl rosca metalizado cl 6 metros



Descrição	PESO PÇ
16x1,55mm 5/8" externo	3,30kg
19x1,25mm 3/4" externo	3,46kg
19x1,55mm 3/4" externo	4,10kg
25x1,25mm 1" externo	4,47kg
25x1,55mm 1" externo	5,74kg
25x1,95mm 1" externo	6,80kg
32x1,25mm 1.1/4" externo	5,79 kg
32x1,55mm 1.1/4" externo	7,00kg
32x1,95mm 1.1/4" externo	8,70kg
38,10x2,70mm 1.1/2" externo	14,20kg
38x1,25mm 1.1/2" externo	6,90kg
38x1,55mm 1.1/2" externo	8,50kg

Descrição	PESO PÇ
38x1,95mm 1.1/2" externo	10,50kg
50,80x1,25mm 2" externo	9,30kg
50,80x2,70mm 2" externo	19,25kg
50x1,55mm 2" externo	11,50kg
50x1,95mm 2" externo	14,30kg
60,30x2,70mm 2.3/8" externo	23,01kg
63x1,55mm 2.1/2" externo	14,20kg
63x1,95mm 2.1/2" externo	17,50kg
63x2,70mm 2.1/2" externo	24,26kg
76x1,95mm 3" externo	22,50kg
76x2,70mm 3" externo	29,36kg

Tubo redondo galv. cl rosca cl 6 metros



Descrição	PESO PÇ
21,20mmx2,00mm (externa) 1/2" interna	6,50kg
21,20mmx2,25mm (externa) 1/2" interna	7,00kg
21,20mmx2,65mm (externa) 1/2" interna	7,90kg
26,90mmx2,00mm (externa) 3/4" interna	8,00kg
26,90mmx2,25mm (externa) 3/4" interna	8,90kg
26,90mmx2,65mm (externa) 3/4" interna	10,10 kg
33,70mmx2,65mm (externa) 1" interna	13,00kg
42,40mmx2,65mm (externa) 1.1/4" interna	16,50kg

Descrição	PESO PÇ
48,30mmx2,65mm (externa) 1.1/2" interna	19,30kg
48,30mmx3,00mm (externa) 1.1/2" interna	20,60kg
48,30mmx3,35mm (externa) 1.1/2" interna	23,00kg
60,30mmx3,00mm (externa) 2" interna	26,80kg
76,10mmx3,35mm (externa) 2.1/2" interna	36,70kg
88,90mmx3,35mm (externa) 3" interna	45,20kg
114,30mmx3,75mm (externa) 4" interna	64,20kg

DICA

Proporcionando ajustes e encaixes perfeitos, os tubos se adaptam a muitas formas de uso. Solicite seu orçamento!



Tubos industriais retangulares

Tubo retangular preto cl 6 metros



Descrição	PESO PÇ
20 x 30 x 0,90mm	4,32kg
20 x 30 x 1,06mm	4,90kg
20 x 30 x 1,20mm	5,73 kg
20 x 30 x 1,50mm	6,80kg
20 x 40 x 0,90mm	5,08kg
20 x 40 x 1,20mm	6,70 kg
20 x 40 x 1,50mm	8,30kg
20 x 40 x 2,00mm	11,30kg
20 x 40 x 3,00mm	16,00kg
20 x 50 x 1,20mm	7,90kg
20 x 50 x 1,50mm	9,70kg
20 x 50 x 2,00mm	12,60kg
30 x 40 x 0,90mm	5,90kg
30 x 40 x 1,06mm	6,90kg
30 x 40 x 1,20mm	7,80kg
30 x 40 x 1,50mm	9,80kg
30 x 40 x 2,00mm	12,60kg
30 x 40 x 2,65mm	17,56kg
30 x 50 x 0,90mm	6,66kg
30 x 50 x 1,06mm	8,00 kg
30 x 50 x 1,20mm	8,93kg
30 x 50 x 1,50mm	11,10kg
30 x 50 x 2,00mm	15,00kg
30 x 60 x 1,20mm	10,00kg
30 x 60 x 1,50mm	12,50kg
30 x 70 x 1,20mm	11,10kg
30 x 70 x 1,50mm	14,10kg
30 x 70 x 2,00mm	18,20kg
30 x 70 x 2,65mm	23,70kg
30 x 90 x 1,20mm	13,40kg
30 x 90 x 1,50mm	17,00kg
40 x 50 x 1,50mm	13,00kg
40 x 50 x 2,00mm	16,90kg
40 x 60 x 1,20mm	11,10kg
40 x 60 x 1,50mm	14,10kg
40 x 60 x 2,00mm	19,00kg
40 x 60 x 3,00mm	27,10kg
40 x 80 x 1,20mm	13,50kg
40 x 80 x 1,50mm	17,00kg

Descrição	PESO PÇ
40 x 80 x 2,00mm	22,50kg
40 x 80 x 3,00mm	32,50kg
40 x 80 x 3,75mm	41,00kg
40 x 80 x 4,25mm	45,30kg
40 x 100 x 1,50mm	20,15kg
40 x 100 x 2,00mm	26,00kg
40 x 100 x 2,65mm	33,83kg
40 x 100 x 3,00mm	38,70kg
50 x 70 x 3,00mm	33,20kg
50 x 70 x 4,25mm	45,30kg
50 x 70 x 4,75mm	52,70kg
50 x 80 x 3,00mm	35,50kg
50 x 100 x 2,00mm	28,90kg
50 x 100 x 3,00mm	42,00kg
80 x 100 x 3,75mm	61,35kg
80 x 100 x 4,25mm	69,20kg
80 x 100 x 4,75mm	77,04kg
80 x 100 x 6,30 mm	100,65kg
100 x 120 x 6,35mm	126,00kg
100 x 150 x 3,00mm	67,70kg
100 x 150 x 3,35mm	74,00kg
100 x 150 x 4,75mm	107,00kg
100 x 200 x 3,00mm	84,30kg
150 x 200 x 6,35mm	205,87kg



Dica

Oferecemos tubos de aço preto em barras de 6 metros de comprimento. Na Tévere você encontra o tubo certo para sua necessidade. Solicite seu orçamento!

Tubos industriais retangulares

Tubo retangular galv. metalizado
cl 6 metros



Descrição	PESO PÇ	Descrição	PESO PÇ
20x30x0,80mm	3,67kg	30x50x1,55mm	11,29kg
20x30x0,95mm	4,30kg	30x70x1,25mm	11,80kg
20x30x1,25mm	5,70kg	40x60x1,25mm	11,55kg
20x30x1,55mm	6,95kg	40x60x1,55mm	14,30kg
20x40x1,25mm	6,90kg	40x80x1,25mm	13,86kg
20x40x1,55mm	8,38kg	40x80x1,55mm	17,10kg
30x40x1,25mm	8,20kg	40x80x1,95mm	21,42kg
30x50x1,25mm	9,30kg		

DICA

Os tubos galvanizados oferecem resistência à compressão e à torção, por isso são considerados itens de estruturação de obras. Solicite seu orçamento!



Tubos industriais oblongos

Tubo oblongo preto cl 6 metros

Descrição	PESO PÇ
16 x 30 x 1,06mm FINA FRIO	3,80kg
16 x 30 x 1,20mm FINA FRIO	4,40kg



Tubos industriais quadrados

Tubo quadrado galv. metalizado
cl 6 metros



Descrição	PESO PÇ	Descrição	PESO PÇ
20x20x0,80mm	2,90kg	40x40x1,25mm	9,20kg
20x20x0,95mm	3,50kg	40x40x1,55mm	11,70kg
20x20x1,25mm	4,60kg	40x40x1,95mm	14,10kg
30x30x0,95mm	5,28kg	50x50x1,55mm	14,25kg
30x30x1,25mm	6,90kg	50x50x1,95mm	17,80kg
30x30x1,55mm	8,40kg		

Tubos industriais quadrados

Tubo quadrado preto cl 6 metros



Descrição	PESO PÇ
15 x 15 x 0,90mm	2,44kg
15 x 15 x 1,06mm	2,90kg
15 x 15 x 1,20mm	3,20kg
15 x 15 x 1,50mm	4,00kg
20 x 20 x 0,90mm	3,37kg
20 x 20 x 1,06mm	3,90kg
20 x 20 x 1,20mm	4,43kg
20 x 20 x 1,50mm	5,40kg
25 x 25 x 1,20mm	5,50kg
25 x 25 x 1,50mm	6,80kg
30 x 30 x 0,90mm	5,00kg
30 x 30 x 1,06mm	5,90kg
30 x 30 x 1,20mm	6,73kg
30 x 30 x 1,50mm	8,30kg
30 x 30 x 2,00mm	11,32kg
30 x 30 x 3,00mm	16,20kg
40 x 40 x 0,90mm	6,70kg
40 x 40 x 1,06mm	7,90kg
40 x 40 x 1,20mm	9,00kg
40 x 40 x 1,50mm	11,10kg
40 x 40 x 2,00mm	15,00kg
40 x 40 x 3,00mm	21,40kg
40 x 40 x 3,75mm	26,70kg
50 x 50 x 1,20mm	11,10kg
50 x 50 x 1,50mm	14,10kg
50 x 50 x 2,00mm	18,80kg
50 x 50 x 2,65mm	24,32kg
50 x 50 x 3,00mm	27,00kg
50 x 50 x 4,25mm	37,30kg
50 x 50 x 4,75mm	41,50kg
60 x 60 x 1,20mm	13,50kg
60 x 60 x 1,50mm	17,00kg
60 x 60 x 2,00mm	22,50kg
60 x 60 x 3,00mm	32,80kg
60 x 60 x 4,75mm	50,22kg

Descrição	PESO PÇ
70 x 70 x 1,50mm	20,00kg
70 x 70 x 2,00mm	25,80kg
70 x 70 x 2,65 mm	34,00kg
70 x 70 x 3,00mm	39,00kg
70 x 70 x 3,75mm	48,00kg
70 x 70 x 4,25mm	53,22kg
80 x 80 x 1,50mm	22,50kg
80 x 80 x 2,00mm	31,00kg
80 x 80 x 2,65mm	39,90kg
80 x 80 x 3,00mm	44,50kg
80 x 80 x 3,75mm	54,30kg
80 x 80 x 4,75mm	68,35kg
80 x 80 x 6,30mm	88,84kg
100 x 100 x 2,00mm	38,30kg
100 x 100 x 2,65mm	50,00kg
100 x 100 x 3,00mm	56,20kg
100 x 100 x 4,75mm	87,00kg
100 x 100 x 6,30mm	115,00kg
120 x 120 x 4,75mm	105,00kg
120 x 120 x 6,30mm	138,00kg
140 x 140 x 4,75mm	123,20kg
140 x 140 x 6,35mm	163,33kg
150 x 150 x 4,75mm	132,00kg
150 x 150 x 6,35mm	175,00kg

Dica:



Os tubos industriais quadrados são extremamente resistentes, fazendo com que as estruturas construídas com os mesmos sejam seguras. Solicite seu orçamento!

ACESSÓRIOS

ACESSÓRIOS

Dispomos dos principais acessórios para serralheria e demais projetos, como disco de corte, roldanas, rodízios, guias, dobradiças, cabo de aço, ponta de lança, parafusos, veda calha, PU, fechaduras, eletrodos e arame mig.

A Tévere mantém a qualidade e adquire os melhores produtos ofertados no mercado, sendo diferencial da empresa o custo-benefício, competência dos profissionais e eficiência em logística. Confira nossa linha de acessórios e solicite seu orçamento.



Eletrodos



Ref.	Descrição
1005	Eletrodo Gerdau 2,50mm 5kg
1004	Eletrodo Gerdau 3,25mm 5kg

Eletrodo 1ª linha - (E6013)

Arame MIG



Ref.	Descrição	Peso
3337	Arame Mig Arcelor 0,80mm	15kg
3057	Arame Mig Arcelor 1,00mm	18kg
3058	Arame Mig Arcelor 1,20 mm	18kg
2203	Arame Mig Standard 0,80mm -IMP	15kg
2204	Arame Mig Standard 1,00mm - IMP	15kg
1010	Arame Mig Standard 1,20mm - IMP	15kg

Arruela

Ref.	Descrição	ACAB.	D. Nominal	D. Interno Mín. Máx.	D. Externo
1005	Arruela Lisa 3/16	PO	4,75	5,4 5,6	15

+/- 800 peças por kg

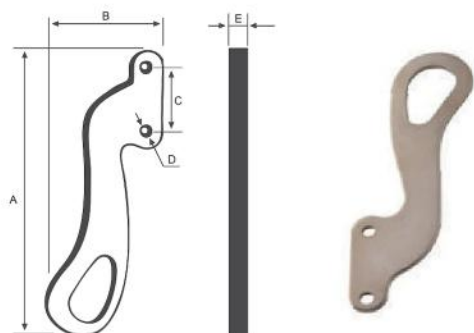

Alavancas

Ref.	Descrição	Acab	A	B	C	D	E
1133	Alavanca Gr. 14,5x2,65x145mm	CR	145	54	35	5,5	2,65
1131	Alavanca Gr. 14,5x2,65x145mm	CV	145	54	35	5,5	2,65
1134	Alavanca Pequena 2,65x125mm	CR	125	80	35	5,5	2,65
1130	Alavanca Peq. 12,5x2,65x125mm	CV	125	80	35	5,5	2,65

Suporte reto

Ref.	Descrição	A	B	C
1127	Suporte Reto Alavanca 80mm	80	16	5
1128	Suporte Reto Alavanca 90mm	90	16	5

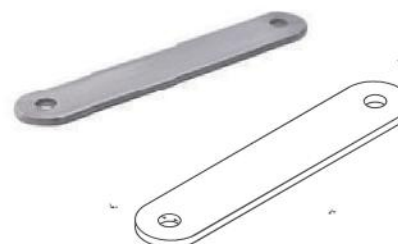

Suporte dobrado

Ref.	Descrição	A	B	C
1129	Suporte Dobrado Alavanca 100mm	100	15	5

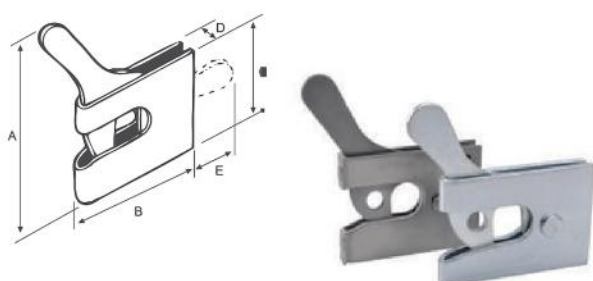
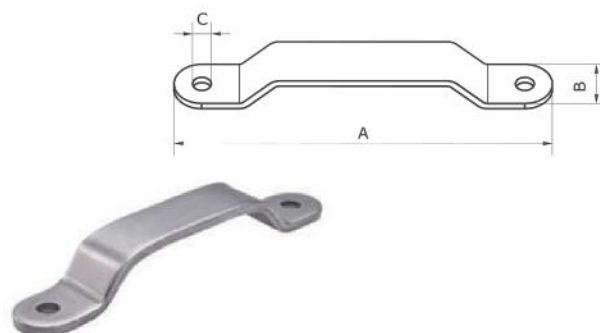

Bate fecha Papagaio

Ref.	Des.	Acab.	A	B	C	D	E
1135	Bate Fecha Papagaio	GV	75	60	44	10	24
1744	Bate Fecha Papagaio	PO	75	60	44	10	24

Fecho portão

Ref.	Des.	Acab.	A	B	C	D	E	F	G
1225	Fecho Portão 100mm	ZA	150	52	49	37	25	17	100
1224	Fecho Portão 75mm	ZA	120	40	49	25	18	17	75

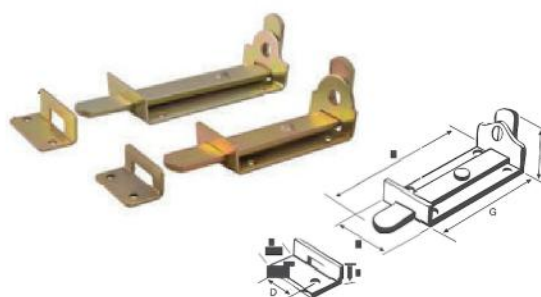

Puxador janela

Ref.	Descrição	Acab.	A	B	C	D
1213	Puxador Janela Centro	CR	80	15	51	5
1211	Puxador Janela Centro	ZB	80	15	17	5

Puxador U aço cromado alça

Ref.	Descrição	Acab.	A	B	C
1212	Puxador U Aço Alça	CR	144	32	18

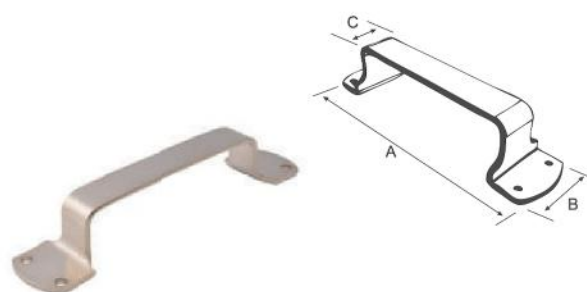

Rebite repuxe

Ref.	Descrição	L (mm)	D1 (mm)	D2 (mm)	L1 (mm)	Esp. Rebitável (mm)	h (mm)
		+/- 0,20	+/- 0,10 - 0	+/- 0,30	- 0 ou		+/- 0,15
1198	Rebite Repuxe Pop	10	3,20mm	6,60	> 25,4	5,00 - 7,00	1,30
1199	Rebite Repuxe Pop	12	3,20mm	6,60	25,4	7,00 - 9,00	1,30
1200	Rebite Repuxe Pop	10	4,00mm	7,80	25,4	4,50 - 6,00	1,55
1201	Rebite Repuxe Pop	12	4,00mm	7,80	25,4	6,00 - 8,00	1,55

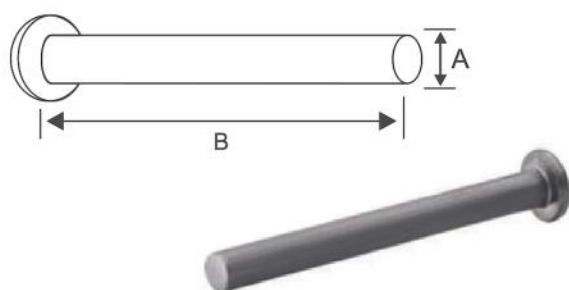
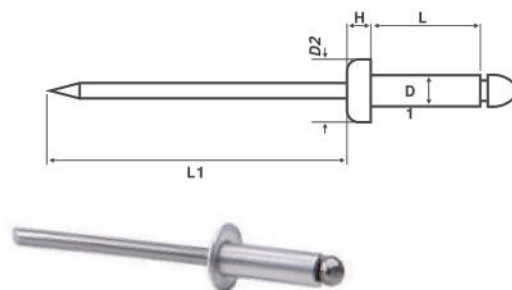

Rebite cabeça chata

Ref.	Descrição	A	B	Qtde p/ kg
1197	Rebite Cabeça Plana Reduzida 3/16x1.3/4	4,75	45	+/- 140 peças
1202	Rebite Cabeça Plana Reduzida 3/16x1/2	4,75	13	+/- 360 peças
1210	Rebite Cabeça Plana Reduzida 3/16x3/4	4,75	19	+/- 280 peças
1204	Rebite Cabeça Plana Reduzida 3/16x3/8	4,75	10	+/- 430 peças

Rodízio duplo com rolamento (ferro)

Ref.	Descrição	Acab.	A	B	C	D
1061	Rod. Duplo 38mm Rol	Ferro	38	45	70	19

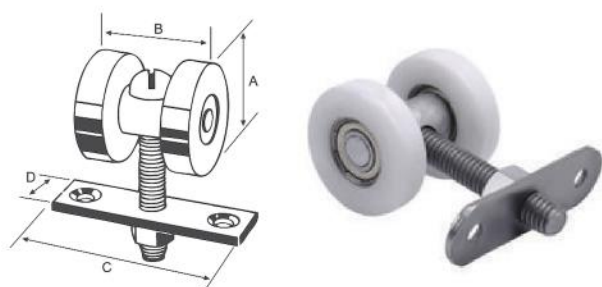

Rodízio duplo com rolamento (nylon)

Ref.	Descrição	Obs.	A	B	C	D
1081	Rod. Duplo Nylon 38mm Rol	Nylon	38	41	70	19

Rodízio duplo sem rolamento (ferro)

Ref.	Descrição	Obs.	A	B	C	D
1071	Rod. Duplo Estampado 38mm S Rol	Estampado	38	42	85	16

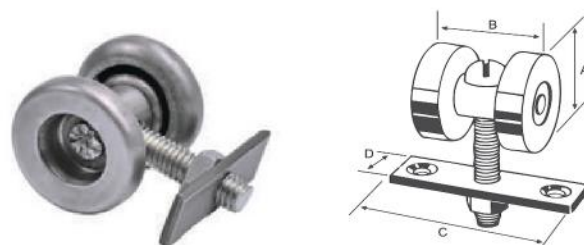

Rodízio janela com regulagem

Ref.	Descrição	A	B	C	D	E
1070	Rodízio 32mm C Regulagem	32	55	23	6	4
1083	Rodízio 38mm C Regulagem	38	55	23	10	6

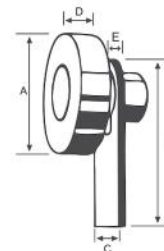

Rodízio janela sem regulagem

Ref.	Descrição	A	B	C	D	E
1750	Rodízio 32mm S Regulagem	32	55	23	6	5
1084	Rodízio 38mm S Regulagem	38	55	23	10	8

Rodízio janela com pino e rolamento

Ref.	Descrição	Obs.	A	B	C	D	E
1082	Rod. Janela Nylon 25mm Pino Rol	Nylon	25	5	6	6,7	5

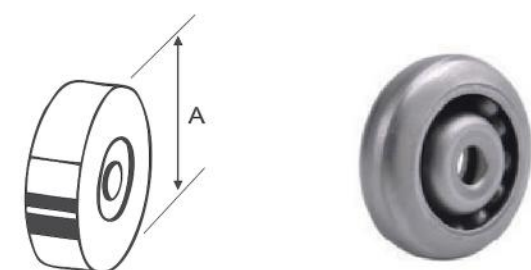
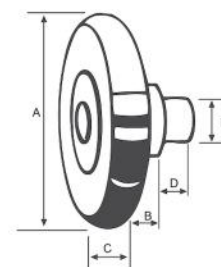

Rodízio janela sem suporte

Ref.	Descrição	Obs.	A
1072	Rodízio Janela Estampado 25mm S sup	Estampado	25

Bucha pantográfica

Ref.	Descrição	Acab.	A	B	C
1115	Bucha Pant Escar 1/2x11,50mm	Escar	11,5	12,7	5,5

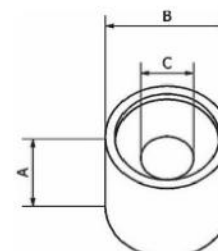

Bucha pantográfica

Ref.	Descrição	Acab.	A	B	C
1116	Bucha Pant N Escar 1/2x13mm	Não Escariado	13	12,7	5,5

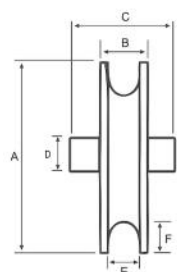
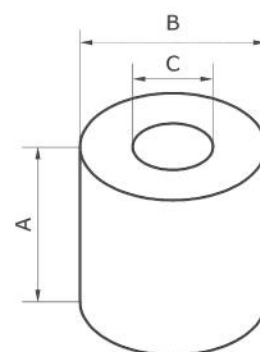

Roldana u 100 p/tubo 1" com pino fixo e rolamento

Ref.	Descrição	Obs.	A	B	C	D	E	F
1074	Roldana U 100 p/tubo 1" Pino Fixo Rol	Ferro	100	28	50	17	20	8

Roldana U parafuso 100mm com rolamento

Ref.	Descrição	Obs.	A	B	C	D	E	F	G
1076	Roldana U Parafuso 100mm Rol	Ferro	100	16	50	12	13,5	6	9,52

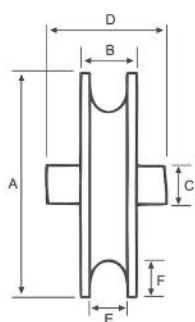
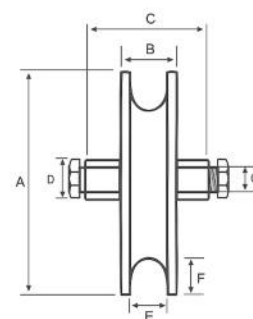

Roldana U com pino e rolamento

Ref.	Descrição	Obs.	A	B	C	D	E	F
1058	Rol. U 75mm Pino Rol	Ferro	75	15	17	80	10	7
1055	Rol. U 100mm Pino Rol	Ferro	100	14	15	100	10	7
1054	Rol. U 125mm Pino Rol	Ferro	125	17	20	100	11	7

Roldana U chato com pino e rolamento

Ref.	Descrição	Obs.	A	B	C	D	E	F
1062	Roldana U Chato 100mm Pino Rol	Ferro	100	16	15	17	8	8
1064	Roldana U Chato 75mm Pino Rol	Ferro	75	15	15	15	8	8

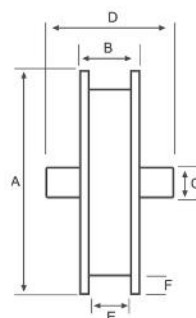

Roldana U nylon com parafuso e rolamento

Ref.	Descrição	Obs.	A	B	C	D	E	F	G
1079	Rol. U Parafuso Nylon 75mm Rol	Nylon	75	20	25	9	11	15	9,52
1077	Rol. U Parafuso Nylon 100mm Rol	Nylon	100	20	25	9	11	17	9,52

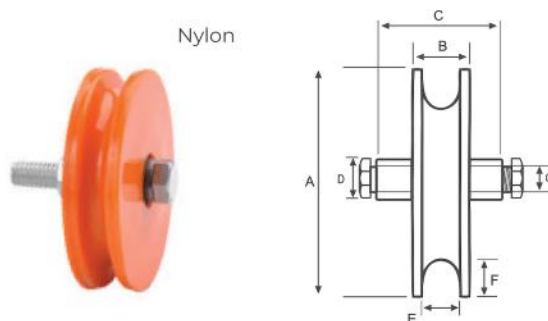

Roldana V com 2 rolamentos

Ref.	Descrição	Obs.	A	B	C	D	E	F
1056	Rol. V 100mm Cant 1.1/4 2 Rol	Ferro	100	30	80	17	25	11
1085	Rol. V 75mm Cant 1.1/2 2 Rol	Ferro	75	30	80	15	25	11
1060	Rol. V 75mm Cant 1.1/4 2 Rol	Ferro	75	30	80	15	25	11
2125	Rol. V 125mm Pino Rol duplo	Ferro	125	32	80	20	25	11

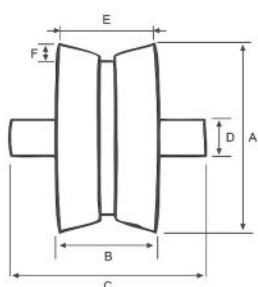

Roldana V com pino e rolamento

Ref.	Descrição	Obs.	A	B	C	D	E	F
1073	Rol. V 100mm Pino Fixo Rol	Ferro	100	16	50	17	14	8
1059	Rol. V 50mm Pino Rol	Ferro	50	15	50	12	13	6
1067	Rol. V 63mm Pino Rol	Ferro	63	15	50	12	14	6
1065	Rol. V 75mm Pino Fixo Rol EX	Ferro	75	15	50	15	14	6

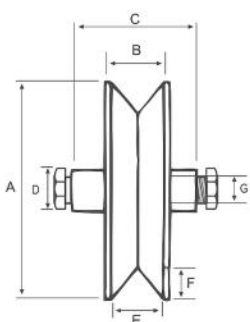
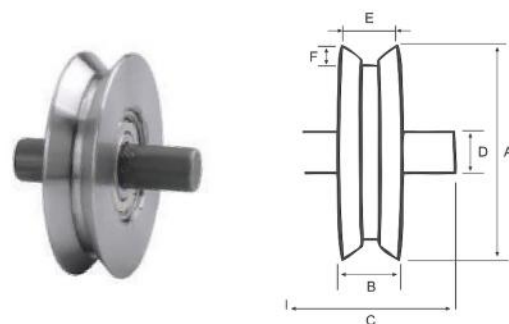

Roldana V com parafuso e rolamento

Ref.	Descrição	Obs.	A	B	C	D	E	F	G
1068	Rol. V Parafuso 63mm Rol	Ferro	63	15	25	12	13	6	4,75
1066	Rol. V Parafuso 75mm Rol	Ferro	75	15	25	15	13	6	9,52

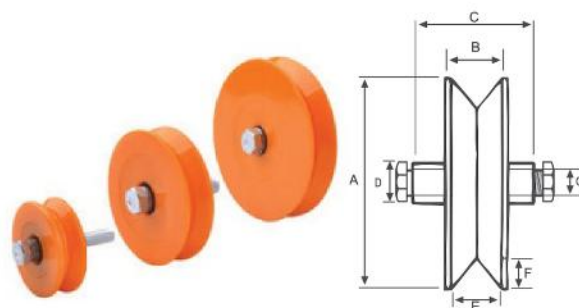

Roldana V com parafuso e rolamento

Ref.	Descrição	Obs.	A	B	C	D	E	F	G
1078	Rol. V Parafuso Nylon 100mm Ro	Nylon	100	20	25	17	13	7	9,52
2032	Rol. V Parafuso Nylon 50mm Ro	Nylon	50	17	25	12	13	7	8
1080	Rol. V Parafuso Nylon 75mm Ro	Nylon	75	20	25	15	13	7	9,52

Acessórios

Dobradiça pino cilíndrica

Ref.	Descrição	A	B
1106	Dobradica Pino Cilindrica 1	25,4	85
1103	Dobradica Pino Cilindrica 1/2	12,7	55
1099	Dobradica Pino Cilindrica 3/4	19,05	80
1102	Dobradica Pino Cilindrica 3/8	9,52	50
1104	Dobradica Pino Cilindrica 5/8	15,87	70
1105	Dobradica Pino Cilindrica 7/8	22,22	80



Dobradiça pino tripla

Ref.	Descrição	A	B	C	D	E	F
1113	Dob. Pino Tripla 3/4	115	19,05	120	12,7	34	42
1100	Dob. Pino Tripla 5/8	83	15,87	90	9,52	24	35
1101	Dob. Pino Tripla 7/8	117	22,22	135	12,7	34	55



Dobradiça pino reversa com aba

Ref.	Descrição	Acab.	Obs.	A	B	C
1110	Dob. Pino Revers 3 FP C/Aba	FP	3 Furos	76,2	63,5	56
1114	Dob. Pino Revers 3.1/2 FP C/Aba	FP	3 Furos	88,9	60,3	66
1660	Dob. Pino Revers 4 FP C/Aba	FP	4 Furos	101,6	66,0	70

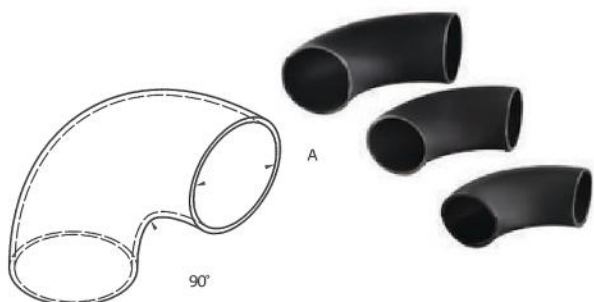
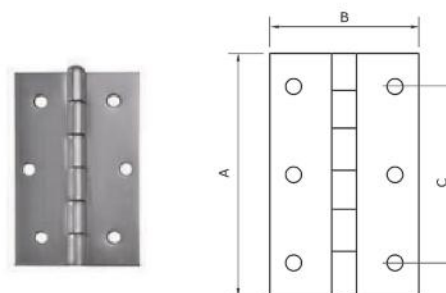

Curva 90°

Ref.	Descrição	Esp.	A
3001	Curva A/C OD 90° Dn 1.1/2" esp. 1,50mm	1,50	1.1/2"
3002	Curva A/C OD 90° Dn 1.1/4" esp. 1,50mm	1,50	1.1/4"
3000	Curva A/C OD 90° Dn 2" esp. 2,00mm	2,00	2"

Ferrolho fio redondo

Ref.	Descrição	Acab.	A	B	C	D	E	F	G	H
1216	Ferrolho Fio Redondo 75mm Leve Trinco	ZB	100	37	45	10	43	15	4	6

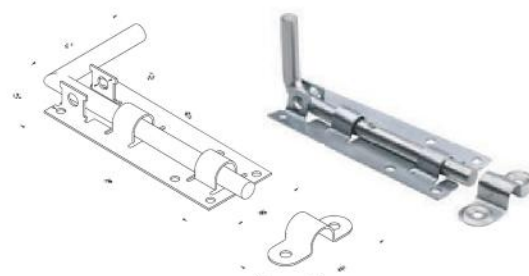

Acessórios

Tampa de tubo

Ref	Descrição	A	B
1270	Quadrado 15x15mm Interna Preta	15	15
1261	Quadrado 20x20mm Interna Preta	20	20
2208	Quadrado 50x50mm Interna Preta	50	50
1262	Retangular 20x30mm Interna Preta	20	30
1268	Retangular 30x40mm Interna Preta	30	40
1263	Retangular 30x50mm Interna Preta	30	50

Ref	Descrição	A
1269	Redondo 19mm Interno Preta	19
1661	Redondo 25mm Interno Preta	25
1264	Redondo 32mm Interno Preta	32
1265	Redondo 38mm Interno Preta	38
1266	Redondo 50mm Interno Preta	50
1267	Redondo 63mm Interno Preta	63

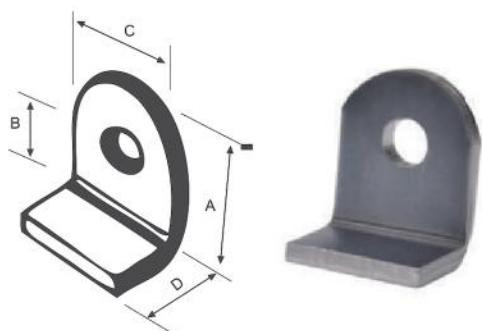

Console 90 graus orelhinha articulada

Ref.	Descrição	Acab.	A	B	C	D
1125	Console 90 Graus Orelhinha Articulada	PO	20	10	18	10

+/- 87 peças por kg

Console reto orelhinha articulada

Ref.	Descrição	Acab.	A	B	C	D	E
1126	Con. Reto Orelhinha Articulada	PO	30	20	18	5,5	2,65

+/- 91 peças por kg

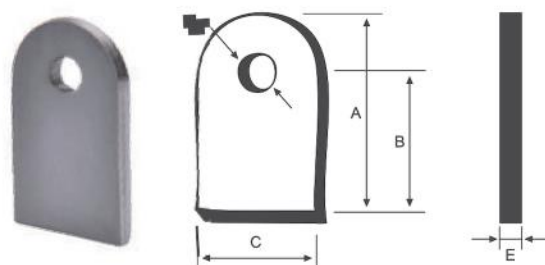

Clips cabo de aço



Ref.	Descrição	Acab.	Medida
2814	Clips Cabo Aço 3/16	ZN	4,75
2815	Clips Cabo Aço 1/4	ZN	6,30
2773	Clips Cabo Aço 5/16	ZN	8,00
2956	Clips Cabo Aço 3/8	ZN	9,50

Acessórios

Cabo de aço

Ref.	Descrição	Medida	Quantidade de Fios
2851	Cabo de Aço 3/16	4,75	6x7
2852	Cabo de Aço 1/4	6,30	6x19
2955	Cabo de Aço 5/16	8,00	6x19

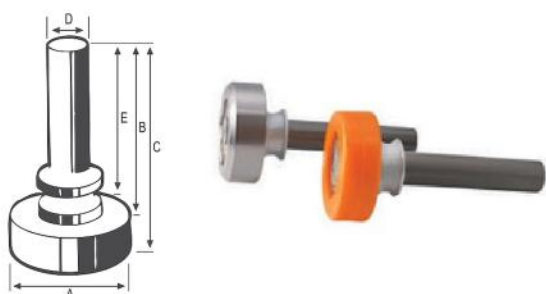

Guia com rolamento com anel

Ref	Descrição	Acab.	Obs	A	B	C	D	E
1751	Guia 48mm Rol C Anel	PO	Ferro	48	80	96	16	62
1097	Guia Nylon 48mm Rol C Anel S Luva	PO	Nylon	48	80	96	16	62

Guia com rolamento sem anel

Ref	Descriçã	Acab	Obs	A	B	C	D
1088	Guia 48mm Rol S Anel	PO	Ferro	48	80	96	16
1087	Guia 68mm Rol S Anel	PO	Ferro	68	80	96	16
1086	Guia 72mm Rol S Anel	PO	Ferro	72	80	96	16
1096	Guia Nylon 48mm Rol S Anel S Luva	PO	Nylon	48	80	96	16

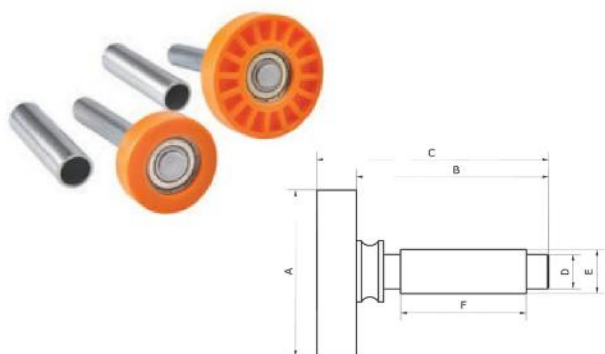

Guia com rolamento com anel e luva

Ref	Descrição	Acab	Obs	A	B	C	D	E	F
1093	Guia Nylon 48mm Rol C Anel C Luva	ZB	Nylon	4	100	116	16	21	70
2668	Guia Nylon 68mm Rol C Anel C Luva	ZB	Nylon	8	68	78	94	15	51
3654	Guia Nylon 72mm Rol C Anel C Luva	ZB	Nylon	71	100	116	15	19	70

Guia sanfona canoinha

Ref	Descriçã	Acab	Obs	A	B	C	D
1090	Guia Sanfona Canoinha	PO	1 Furo	14	45	11	5

+/- 112 peças por kg

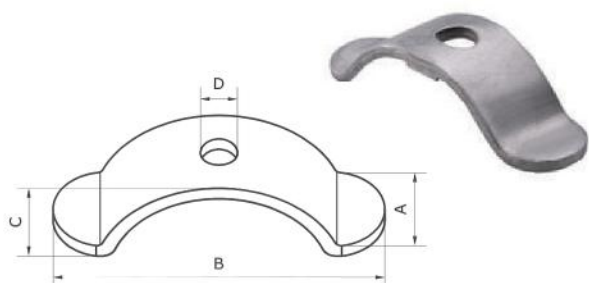

Guia sanfona U

Ref.	Descrição	Acab.	A	B	C
1095	Guia Sanfona U	PO	18	14	15

+/- 140 peças por kg

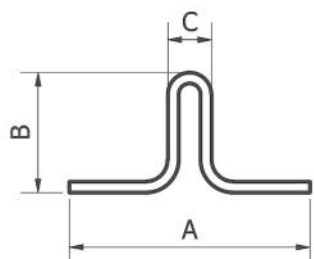
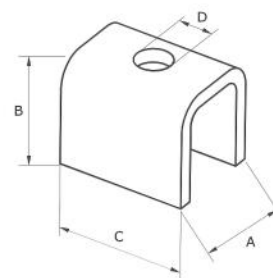

Guia trilho T menor

Ref.	Descrição	Acab.	A	B	C
1092	Guia Trilho T Menor	44	22	8	16

+/- 60 peças por kg

Guia trilho T maior

Ref.	Descrição	A	B	C	D
1091	Guia Trilho T Maior	43	32	11	16

+/- 50 peças por kg

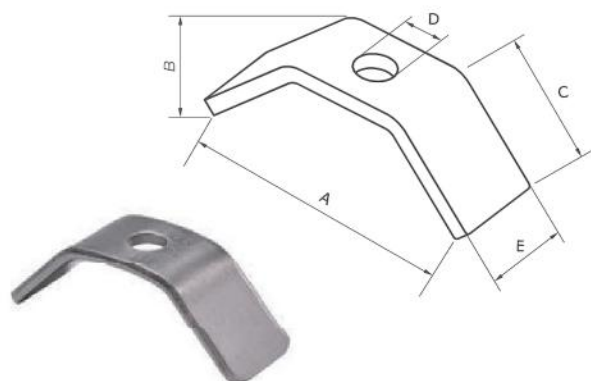
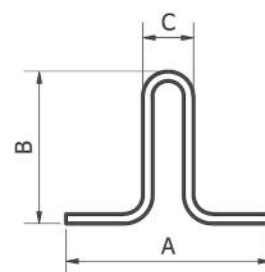

Guia sanfona 45°

Ref.	Descrição	Acab.	A	B	C	D	E
1098	Guia Sanfona Canoinha 1/2X11	PO	36	12	15	5	12

Acessórios

Haste

Ref.	Acab.	Obs.	A	B
1038	Haste Pantográfica	3 Furos	250	16
1039	Haste Pantográfica	3 Furos	300	16
1040	Haste Pantográfica	5 Furos	500	16
1041	Haste Pantográfica	5 Furos	600	16
1042	Haste Pantográfica	Escar	3 Furos	250
1043	Haste Pantográfica	Escar	3 Furos	300
1044	Haste Pantográfica	Escar	5 Furos	500
1045	Haste Pantográfica	Escar	5 Furos	600

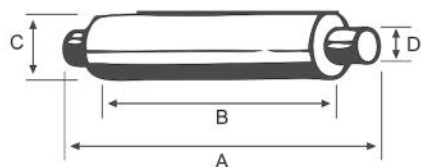
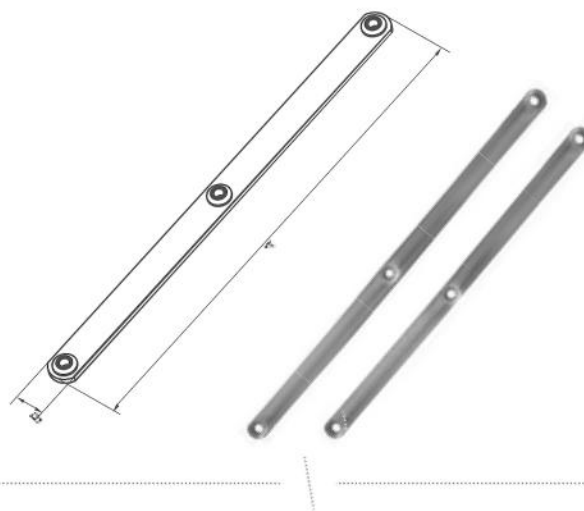

Pino pantográfico

Ref.	Descrição	Acab.	A	B	C	D
1117	Pino Pant 5/16x45mm	PO	45	35	8	5

Veda calha e pu

Ref.	Descrição
1139	Veda Calha Alumínio 280g
3873	Veda Calha PU Cinza 400g



PU

Veda Calha

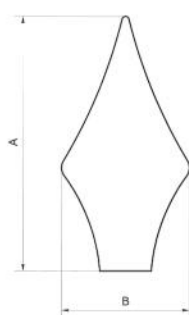

Ponta de lança

Ref.	A	B	Qtde p/kg	
1118	Ponta Lança Pequena 3/8	65	38	+/- 42 peças
1119	Ponta Lança Comum 1/2	77	44	+/- 30 peças

Acessórios

Ponta de lança

Ref.	Descrição	Acab.	A	B
1122	Ponta Lança Comum FP 96x2,00mm	FP	96	45

+/- 27 peças por kg

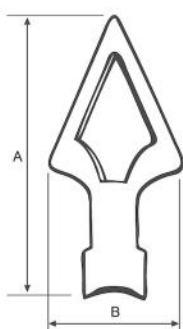
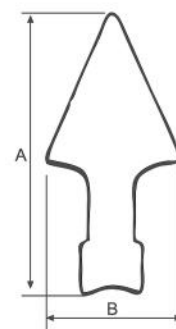

Ponta de lança

Ref.	Descrição	A	B
1121	Ponta Lança Vazada FP 96x2,00m	96	45

+/- 34 peças por kg

Ponta de lança

Ref.	Descrição	A	B
1120	Ponta Lança Vazada 1/2 74mm	74	37

+/- 37 peças por kg

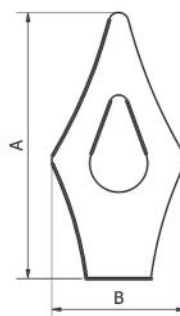

Barra rosqueada



Ref.	Descrição	Acab.	Dim.
1251	Barra Rosq. 1/4 - 20 Fios	FP	6,35mm
1253	Barra Rosq. 5/16 - 18 Fios	FP	8,00mm
1254	Barra Rosq. 3/8 - 16 Fios	FP	9,52mm
1256	Barra Rosq. 1/2 - 13 Fios	FP	12,50mm
1258	Barra Rosq. 5/8 - 11 Fio	FP	15,87mm
1252	Barra Rosq. 1/4 - 20 Fios	ZB	6,35mm
1260	Barra Rosq. 5/16 - 18 Fios	ZB	8,00mm
1255	Barra Rosq. 3/8 - 16 Fios	ZB	9,52mm
1257	Barra Rosq. 1/2 - 13 Fios	ZB	12,50mm
1259	Barra Rosq. 5/8 - 11 Fios	ZB	15,87mm

Discos

Ref.	Descrição
1166	Disco Corte Inox 4.1/2x7/8x1,00mm Norton
1174	Disco Corte Inox 7x7/8x1,6mm Norton
3075	Disco Corte Cab 32 7POL 1/16x7/8 Redescor inox
1152	Disco Corte Cab 32 7POL 1/8x7/8 Redescor
2970	Disco Corte Cab 32 7POL 1/8x7/8 Norton
2905	Disco Corte Cab 32 9POL 1/8x7/8 Norton
1165	Disco Corte Cab 32 9POL 1/8x7/8 Redescor
1153	Disco Corte Cab 32 10POL 1/8x1 Redescor
4118	Disco Corte Cab 32 12POL 1/8x1 Norton Imp
1154	Disco Corte Cab 32 12POL 1/8x1 Redescor
1159	Disco Desbaste 7POL 1/4x7/8 Norton
1156	Disco Desbaste Dab 760 7POL 1/4x7/8 Redescor
4238	Disco Flap 4.1/2x7/8 Grana 40 Evolution
1747	Disco Flap 4.1/2x7/8 Grana 40 Norton Imp.
4239	Disco Flap 4.1/2x7/8 Grana 60 Evolution
3611	Disco Flap 4.1/2x7/8 Grana 60 Norton Imp.



Chapéu para coluna de ferro

Ref.	Descrição	A	B	C
4190	Chapéu P/Coluna de Ferro 50x50	50	50	1,5
4191	Chapéu P/Coluna de Ferro 60x60	60	60	1,5
4192	Chapéu P/Coluna de Ferro 80x80	80	80	1,5
4193	Chapéu P/Coluna de Ferro 100x100	100	100	1,5

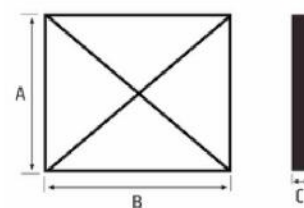

Chapéu para coluna de ferro

Ref.	Descrição	A	B
14194	Chapéu Redondo P/Coluna 2 (1.50x58mm)	2"	1,50

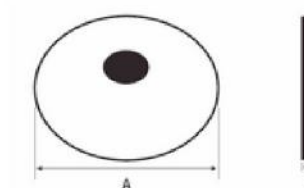

Acessórios

Parafuso hexa para telha e autobrocante

Ref	Ød	L	A	C	Descrição
2748	5,50	19,05	9,00	6,85	Parafuso Hexa p/Telha Terça 12-3/4-5/16 (100un)
2749	6,30	22,20	5,00	6,85	Parafuso Hexa p/Telha Costura 14-1/4x7/8-5/16 (100un)
3491	5,50	19,05	8,00	3,90	Parafuso Hexa p/Telha Terça tratado 12-3/4-5/16 (100un)

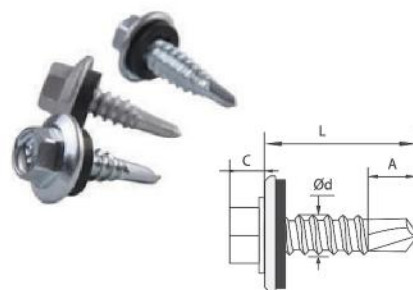

Parafuso hexa para telha e autobrocante

Ref	Ød	L	A	C	Descrição
4350	5,00	54,00	9,00	3,00	Parafuso Autobrocante ZC p/ Telha 12x2" (100 un)

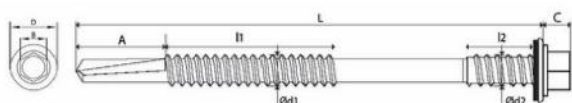
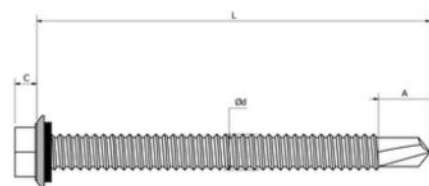

Parafuso para telha EPS

Ref	A	B	C	D	II	I2	Ød1	Ød2
2812	12,00	7,85	6,85	14,50	38,00	14,00	4,00	4,80

Descrição: Parafuso Autobrocante 12x4 - Rosca dupla Zincado (100un)

Parafuso para madeira

Ref.	B	C	D	L	Ø	Descrição	
2811	8,00	3,90	14,00	40,10	4,80	9,00	Parafuso. Autobrocante 12x1 1/2 (100un) Tratado p/ madeira
3004	8,00	3,90	14,00	76	5,50	5,00	Parafuso. Autobrocante 12x3 (100un) Tratado p/ madeira
3610	8,00	3,90	14,00	110	5,50	8,00	Parafuso. Autobrocante 12x4 5/16 (100un) Tratado p/ madeira

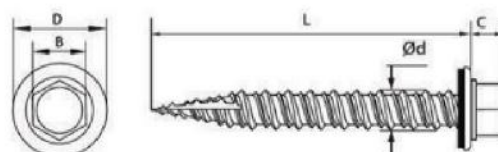

Parafuso cabeça flangeada

Ref.	D	K	L	Y	Ød	Descrição	
2850	10,80	2,70	17,30	4,80	3,40	9,00	Parafuso Cabeça Flangeada 4.2x19 Ponta Broca (100un)

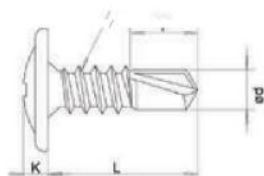

Fechadura Stam - Linha 502/602

Ref.	Acab.	Descrição
1237	Grafite	Fechadura Estr Grafit 40mm 602/03 Stam
1247	Grafite	Fechadura Media Grafit 50mm 502/03 Stam

Fechadura Stam - Linha 501/602/603

Ref.	Acab.	Descrição
1231	Grafite	Fechadura Estr 40mm 603/03 Stam
1236	Inox	Fechadura Estr Inox 40mm 602/03 Stam

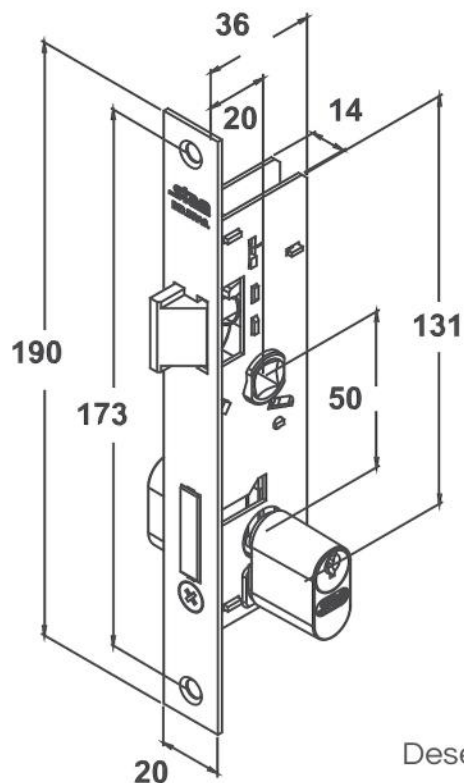

Desenho técnico linha 601/602/603

Fechadura Stam - Linha 803

Ref.	Acab.	Descrição
1229	Grafite	Fechadura Larg 60mm 803/03

Ref.	Acab.	Descrição
1228	Inox	Fechadura Larg Inox 60mm 803/11 Stam

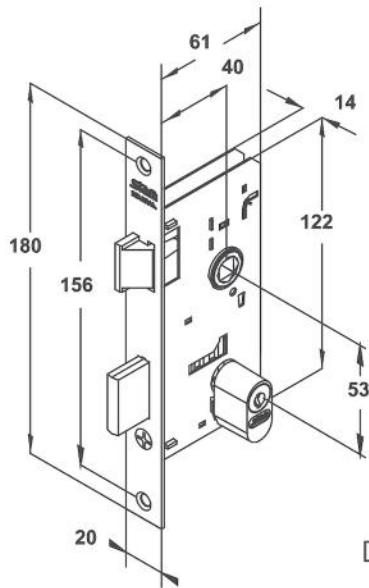

Desenho técnico linha 803



Fechadura Stam - linha 901

Ref.	Acab.	Descrição
1240	Grafite	Fechadura Porta Correr Grafite 901 Stam

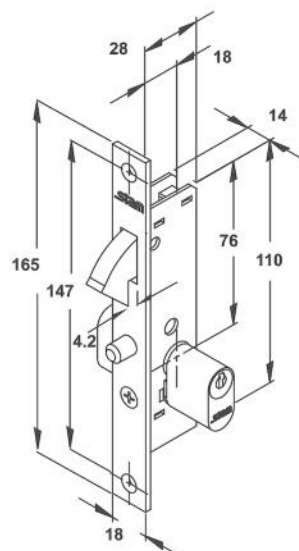

Desenho técnico linha 901



Fechadura Stam - Linha 201

Ref.	Acab.	Descrição
1238	Grafite	Fechadura Porta Rolo Grafite 201 Stam

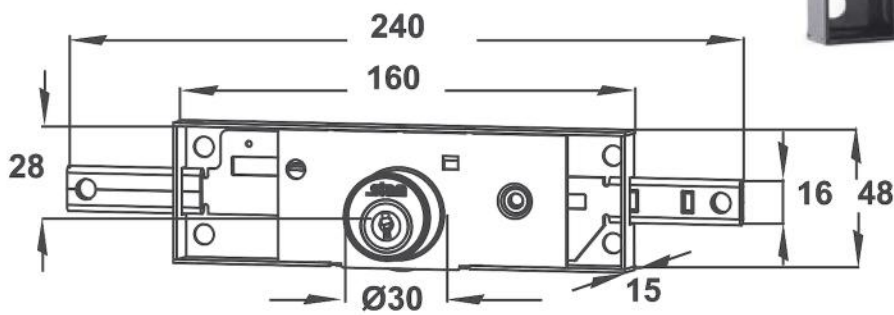

Maçanetas

Ref.	Acab.	Descrição
1244	Cromado	Maçaneta Fechadura CR 114

Telhas

- Telha TP-40
- Telha ondulada
- Telha TP-25

TELHAS

As telhas têm grande participação nos projetos de construção civil, desta forma oferecemos o que há de melhor e mais qualificado no mercado.

As Telhas Tévere são produtos resistentes, com alta qualidade e durabilidade, proporcionando a redução de manutenções. O uso de Telhas de Aço para coberturas e fechamentos laterais são opções técnicas para uma construção rápida e econômica, são muito versáteis e, por isso, podem ser utilizadas em diferentes meios, como galpões, prédios industriais, residências e edifícios.

Portanto, investir em materiais reconhecidos é a maneira ideal de obter o melhor resultado em sua obra, sem preocupações futuras.

A Tévere oferece os produtos com a mais alta qualidade, em diversas cores e modelos. Escolha o que melhor se encaixa ao seu projeto.

Telha TP - 40

Telha trapezoidal TP-40

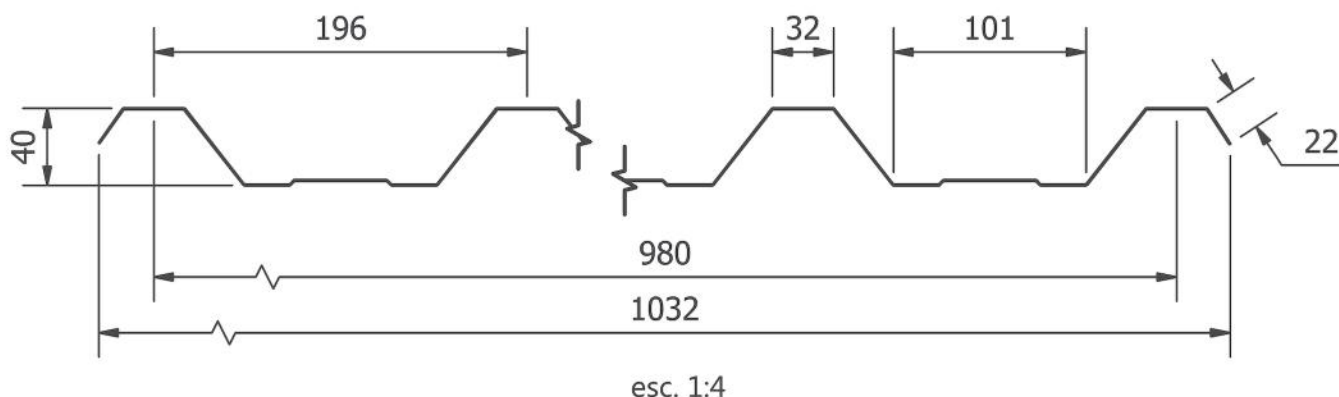

Telha Trapezoidal TP-40
 Largura Total: 1032mm
 Largura Útil: 980mm
 Comprimento máximo: 12 metros por telha

Acabamento	Espessura	PESO kg/m
Aluzinco	CH. 0,43	3,73 kg/m
Aluzinco	CH. 0,50	4,41 kg/m

Telhas pré-pintadas

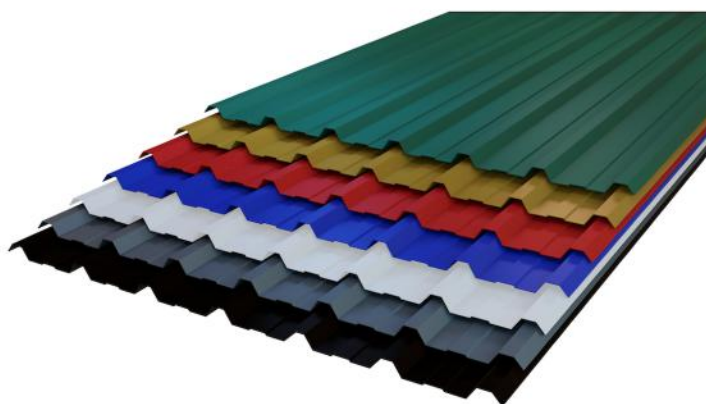

Telha Aluzinco Pré-Pintadas nas cores:



Acabamento	Espessura	PESO kg/m
Amarelo	CH.0,50	4,70 kg/m
Azul	CH.0,50	4,70 kg/m
Branco	CH.0,50	4,40 kg/m
Verde	CH.0,50	4,70 kg/m
Vermelho	CH.0,50	4,62 kg/m

Acabamento	Espessura	PESO kg/m
Azul	CH.0,43	4,00 kg/m
Branco	CH.0,43	3,90 kg/m
Cinza	CH.0,43	3,78 kg/m
Preto	CH.0,43	3,94 kg/m
Verde	CH.0,43	4,00 kg/m
Vermelho	CH.0,43	4,00 kg/m

Telha ondulada

Telha ondulada 17

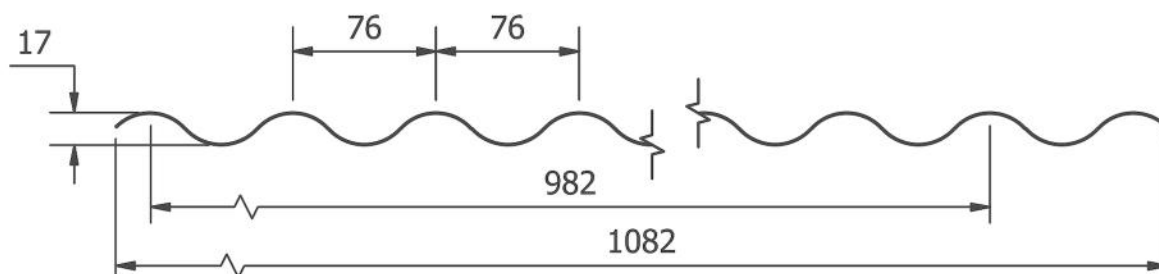

esc. 1:4

Telha ondulada 17
 Largura Total: 1082mm
 Largura Útil: 980mm
 Comprimento máximo: 12 metros por telha

Acabamento	Espessura	PESO kg/m
Aluzinco	CH. 0,43	3,73 kg/m
Aluzinco	CH. 0,50	4,41 kg/m
Aluzinco	CH. 0,65	6,13 kg/m

Telhas pré-pintadas

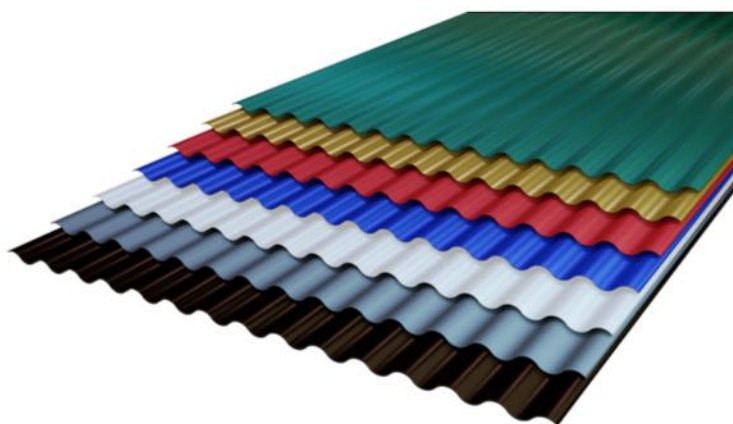

Telha Aluzinco Pré-Pintadas nas cores:



Acabamento	Espessura	PESO kg/m	Acabamento	Espessura	PESO kg/m
Amarelo	CH.0,50	4,70 kg/m	Azul	CH.0,43	4,00 kg/m
Azul	CH.0,50	4,70 kg/m	Branco	CH.0,43	3,90 kg/m
Branco	CH.0,50	4,40 kg/m	Cinza	CH.0,43	3,78 kg/m
Verde	CH.0,50	4,70 kg/m	Preto	CH.0,43	3,94 kg/m
Vermelho	CH.0,50	4,62 kg/m	Verde	CH.0,43	4,00 kg/m
			Vermelho	CH.0,43	4,00 kg/m

Telha TP - 25

Telha Trapezoidal TP-25

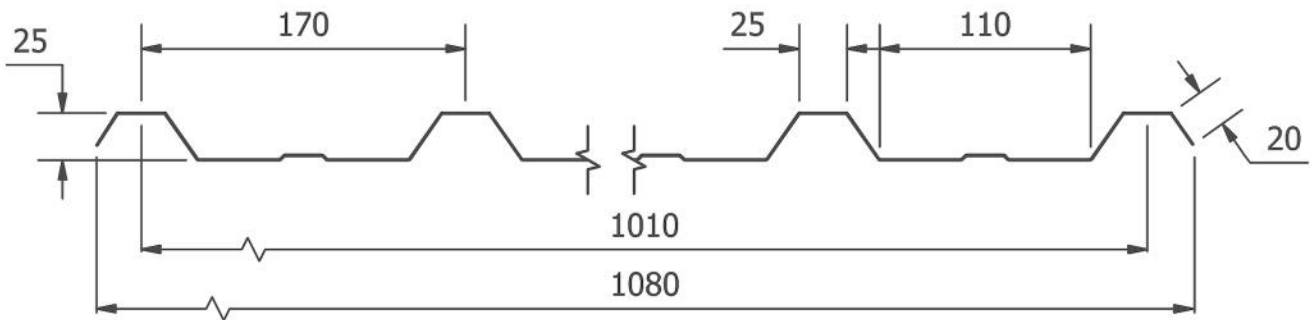

esc. 1:4

Telha Trapezoidal TP-25

Largura Total: 1080mm

Largura Útil: 1010mm

Comprimento máximo: 12 metros por telha

Acabamento	Espessura	PESO kg/m
Aluzinco	CH. 0,43	3,73 kg/m
Aluzinco	CH. 0,50	4,41 kg/m

Telhas pré-pintadas

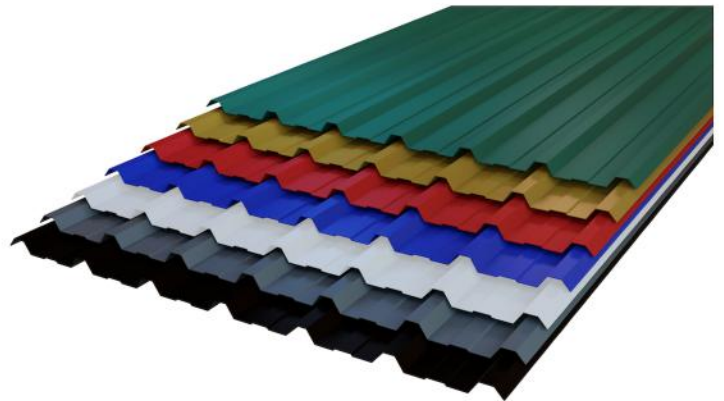

Telha Aluzinco Pré-Pintadas nas cores:

Verde RAL 6002	Amarelo RAL 1003	Vermelho RAL 3000	Azul RAL 5010	Branco RAL 9003	Cinza RAL 7040	Preto RAL 9005

Acabamento	Espessura	PESO kg/m	Acabamento	Espessura	PESO kg/m
Amarelo	CH.0,50	4,70 kg/m	Azul	CH.0,43	4,00 kg/m
Azul	CH.0,50	4,70 kg/m	Branco	CH.0,43	3,90 kg/m
Branco	CH.0,50	4,40 kg/m	Cinza	CH.0,43	3,78 kg/m
Verde	CH.0,50	4,70 kg/m	Preto	CH.0,43	3,94 kg/m
Vermelho	CH.0,50	4,62 kg/m	Verde	CH.0,43	4,00 kg/m
			Vermelho	CH.0,43	4,00 kg/m

Telhas isotérmicas

- Modulada
- Lisa com filme
- Lisa sem filme
- Sanduíche
- Telha forro

TELHAS ISOTÉRMICAS

As telhas isotérmicas mantêm a temperatura estável, funcionando como um isolamento entre um ambiente e outro. São produzidas com materiais e estruturas que dificultam a passagem do calor para o interior do imóvel/obra, amenizando sua temperatura.

Também são chamadas de “telha sanduíche”, pois são feitas com uma camada de material isolante entre duas camadas de telha.

Há vários benefícios para quem investe em uma telha isotérmica.

- Maior conforto térmico
- Alta durabilidade
- Melhor relação entre custo e benefício
- Estrutura mais leve

Conheça a linha de Telhas Isotérmicas da Tévere, os produtos são de alta qualidade, que garantem a segurança e economia para nossos clientes.

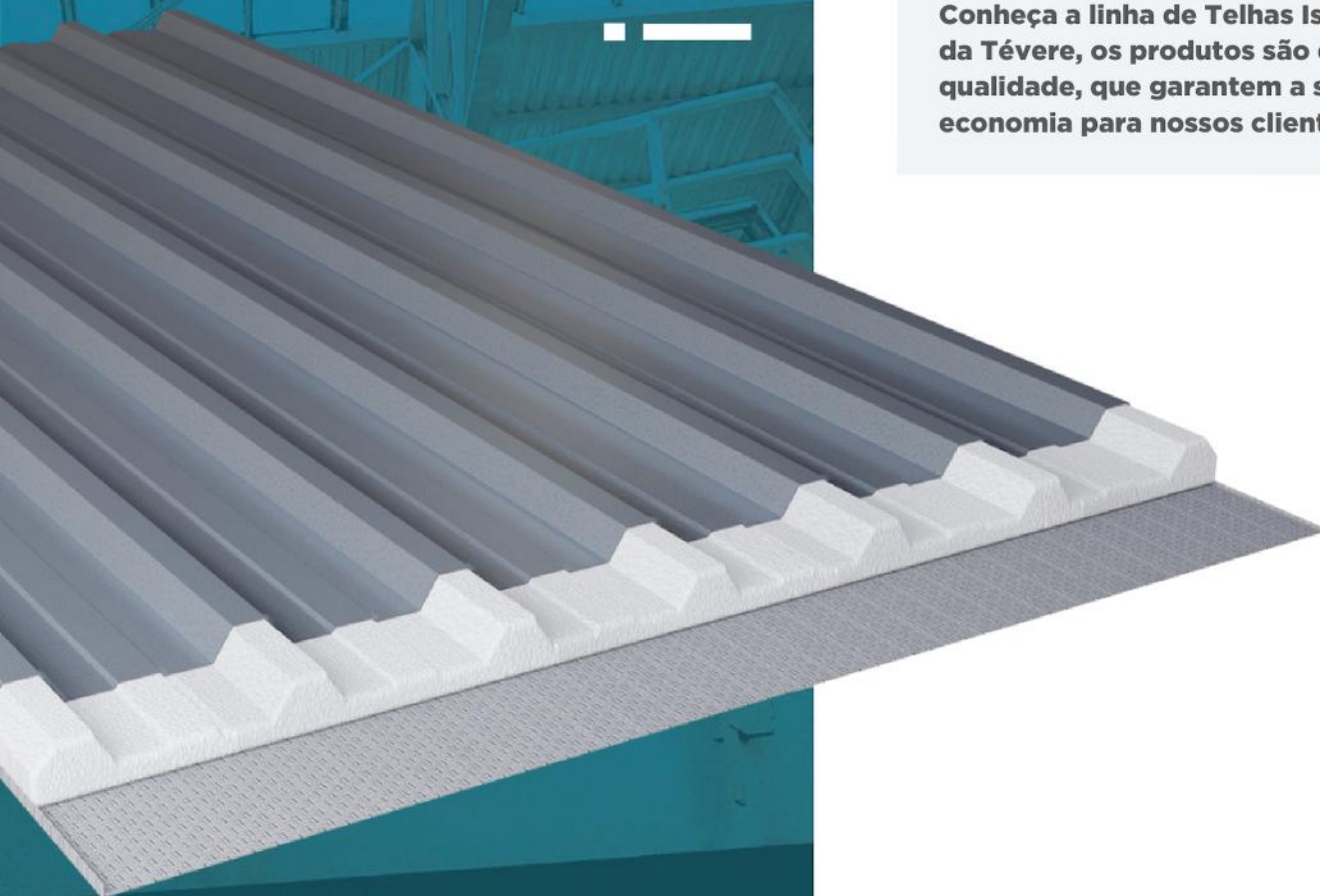

Telhas isotérmicas



- Suporta temperatura mínima de -150°C e máxima de aproximadamente de $+85^{\circ}\text{C}$;
- Alto poder de isolamento térmico;
- Isolamento acústico na espessura de 30mm bloqueia de 40 a 45 decibéis, o que garante a eficiência nos dias de chuva, amortecendo 95 % do impacto do pingo d'água e neutralizando o ruído;
- Densidade média $3\text{kg}/\text{m}^3$;
- Condução de calor: $0,028\text{ Kcal}/\text{h.m.}^{\circ}\text{C}$;
- Isolamento do EPS 30mm retém 85% do calor gerado na fonte;
- Material tipo F, retardante a chamas;
- É imputrescível, não mofa e não desintegra;
- Não contém CFC (Cloro Flúor Carbono) sem prejuízos a camada de ozônio;
- Modelo de telha: Trapézio TP-40 e TP-25;
- Comprimento máximo: 12 metros por telha;
- Espessura do isopor: 30mm;
- Espessura da chapa: 0,43 e 0,50;
- Modelos de EPS: Modulada, Lisa com filme, Lisa sem filme, Sanduíche e Telha Forro.

Telhas isotérmicas (eps) – Isopor 30mm

Modulada

Acabamento	Espessura	PESO kg/m
Aluzinco	CH. 0,43	4,31 kg/m
Aluzinco	CH. 0,50	4,99 kg/m

Modelos:

→ TP-40

→ TP-25



Lisa com filme

Acabamento	Espessura	PESO kg/m
Aluzinco	CH. 0,43	4,95 kg/m
Aluzinco	CH. 0,50	5,63 kg/m

Modelos:

→ TP-40

→ TP-25



Lisa sem filme

Acabamento	Espessura	PESO kg/m
Aluzinco	CH. 0,43	4,34 kg/m
Aluzinco	CH. 0,50	5,02 kg/m

Modelos:

→ TP-40

→ TP-25



Telhas isotérmicas (eps) – Isopor 30mm

Sanduiche

Acabamento	Espessura	PESO kg/m
Aluzinco	CH. 0,43	8,29 kg/m
Aluzinco	CH. 0,50	9,65 kg/m



Modelos:

→ TP-40

→ TP-25



Telha forro

Acabamento	Espessura	PESO kg/m
Aluzinco	CH. 0,43	8,10 kg/m
Aluzinco	CH. 0,50	8,78 kg/m

Modelos:

→ TP-40

→ TP-25

Dica:

Temos também a opção de Telhas com forro em aluzinco colorido. Solicite seu orçamento!



Telhas translúcidas

TELHAS TRANSLÚCIDAS

Devido sua alta resistência e durabilidade as Telhas Translúcidas atendem as variadas necessidades da construção civil. Especialmente, sistemas de cobertura e fechamentos laterais que ampliam significativamente a luminosidade dos ambientes, por serem fabricadas com proteção contra raios UV.

As Telhas Translúcidas são reconhecidas no mercado por serem leves, resistentes e de fácil manuseio. São bastante indicadas para todo tipo de edificação, ambientes comerciais e residenciais, sobretudo indústrias e galpões. Para grandes empreendimentos, seu compromisso sustentável é de grande valor, por promover economia de energia e durabilidade do produto e diminuindo custos.

Telhas translúcidas

Telhas translúcidas



- Boa resistência a impactos;
- Redução no consumo de energia com iluminação;
- Passagem de iluminação de até 70%;
- Superfície totalmente lisa e impermeável;
- Alta durabilidade;
- Proteção contra raios UV;
- Não amarela;
- Material reciclável;
- Leveza e Flexibilidade;
- Comprimento padrão 6 metros;
- Modelo das telhas: TP-40, Ondulada e TP-25.

TP-40

Modelo	Esp.	Largura	Comp.	Material
TP-40	1,50	1060	6000mm	Polipropileno



Ondulada

Modelo	Esp.	Largura	Comp.	Material
Ondulada	0,80	1100	6000mm	Polipropileno

TP-25

Modelo	Esp.	Largura	Comp.	Material
TP-25	1,00	1020	6000mm	Fibra de Vidro

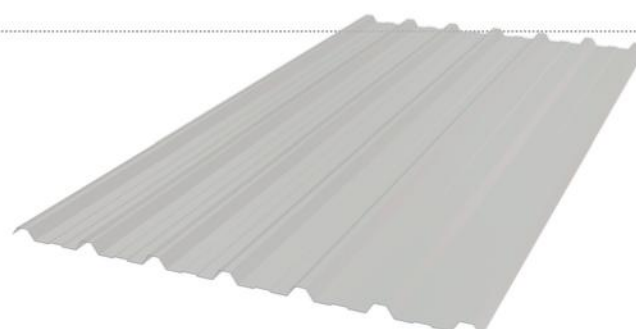

Cumeeira e multidobra

- Cumeeira
- Multidobra

FAMÍLIA CUMEEIRA E MULTIDOBRA

A Cumeeira é necessária em todos os projetos de construções de localidade como residências, galpões, garagens dentre outros. Ela tem como objetivo impedir a infiltração da água da chuva, visto que a água tende a se acumular em vãos das coberturas. Vantagens: Alta resistência à corrosão e fácil instalação.

As Telhas Multidobras têm uso altamente flexível, ideal para acabamento entre a cobertura e o fechamento.

Vantagens: Mais eficiência e beleza aos projetos, ótimo acabamento e altamente durável. A Tévere tem em seu mix de produtos as opções de Cumeeiras e Multidobras nas mais variadas espessuras e modelos, confira nossa linha de materiais.

Cumeeira

Ondulada ou Trapezoidal

Ondulada ou Trapezoidal
Espessuras: 0,43mm ou 0,50mm



Multidobras

TP-25 e TP-40

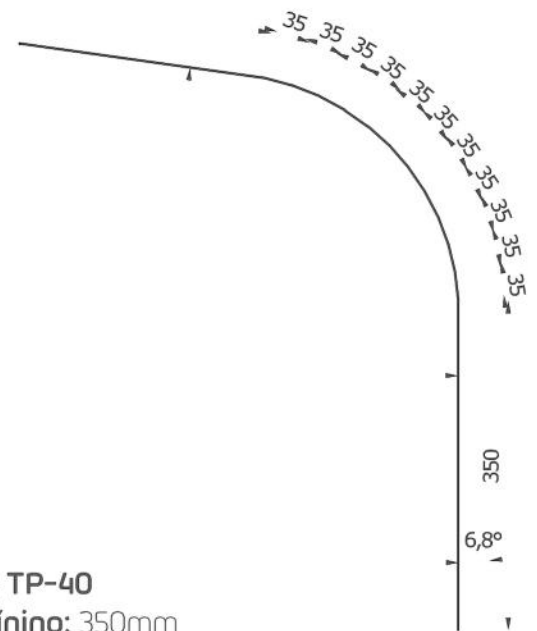

TP-25 e TP-40
Início mínimo: 350mm
Início máximo por batida: 6,4°
Grau máximo: 85° - 13 batidas
Tamanho mínimo da batida: 35mm
Raio conforme as batidas.

Cumeeira e Multidobras disponíveis nas cores:



Verde
RAL 6002



Amarelo
RAL 1003



Vermelho
RAL 3000



Azul
RAL 5010



Branco
RAL 9003



Cinza
RAL 7040



Preto
RAL 9005

TÉVERE

FORTE EM AÇO

www.tevere.com.br
49 3344.8600

Acesso Leste, 1147 - São Francisco
São Lourenço do Oeste - SC 89990-000

 [tevere.aco](https://www.instagram.com/tevere.aco)   [Tévere forte em aço](https://www.linkedin.com/company/tevere)