

# Perfis

- Perfil estrutural perfiladeira
- Perfil estrutural dobradeira
- Perfil "L" cantoneira dobrada
- Perfil "U" serralheiro
- Perfil para porta de rolo
- Perfil para pantográfica

## FAMÍLIA PERFIS

Os perfis de aço Tévere são produzidos de acordo com as normas nacionais e dentro dos mais rigorosos padrões de qualidade.

Fornecemos produtos em tamanho padrão ou de acordo com a necessidade do cliente. Também possuímos uma ampla variedade de espessuras e medidas, como chapas Fina Frio, Fina Quente, Galvanizada, Cosa Cor, A36, Civil 300, que possibilitam melhores soluções de encaixes e acabamentos no seu produto final.

Devido à alta qualidade de nosso acabamento, os perfis Tévere podem ser usados em aplicações aparentes para composição de estruturas metálicas, fachadas e coberturas.

# Perfil Estrutural Perfiladeira

## T8 - Terças Enrijecidas com 6m

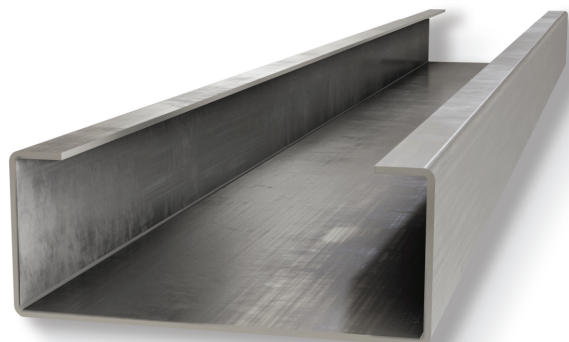
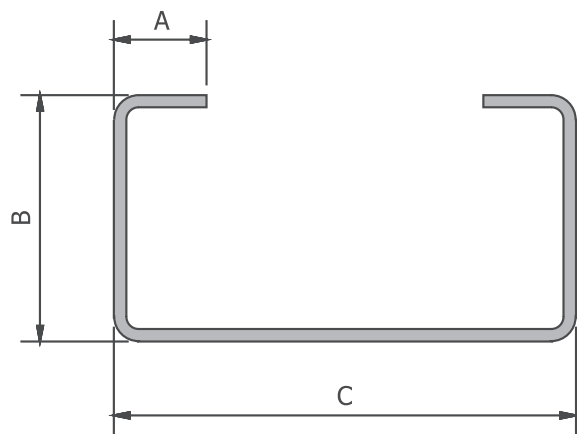

esc. 1:1

A	B	C	CH	kg/m
10	25	50	2,00	1,66
10	25	50	2,25	1,84
10	25	50	2,65	2,09
10	25	50	3,00	2,30
16	40	75	2,00	2,74
16	40	75	2,25	3,04
16	40	75	2,65	3,51
16	40	75	3,00	3,91
15	40	100	2,00	3,10
15	40	100	2,25	3,46
15	40	100	2,65	4,00
16	40	100	3,00	4,51
17	50	100	2,00	3,49
17	50	100	2,25	3,89
17	50	100	2,65	4,51
17	50	100	3,00	5,04
17	50	126	2,00	3,90
17	50	126	2,25	4,36
17	50	126	2,65	5,06
17	50	126	3,00	5,66

A	B	C	CH	kg/m
20	60	150	2,00	4,70
20	60	150	2,25	5,26
20	60	150	2,65	6,12
20	60	150	3,00	6,86
25	75	200	2,00	6,06
25	75	200	2,25	6,88
25	75	200	2,65	8,03
25	75	200	3,00	9,02



### DICA

Além dos materiais produzidos com medidas padrão, produzimos peças com comprimentos/medidas especiais.

**Consulte-nos!**

# Perfil Estrutural Perfiladeira

## T9 - Perfil U com 6m

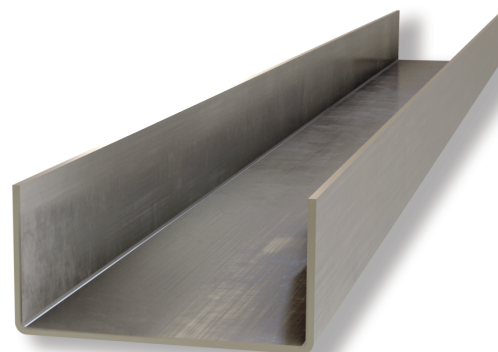
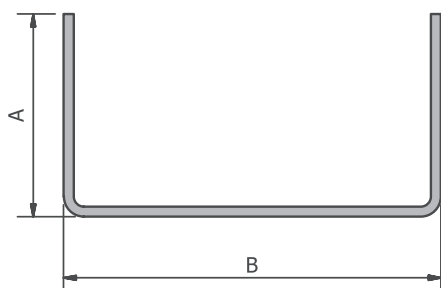

A	B	CH	kg/m
U DE FORA			
25	50	2,00	1,47
25	50	2,25	1,64
25	50	2,65	1,90
25	50	3,00	2,11
U DE FORA			
40	75	2,00	2,35
40	75	2,25	2,63
40	75	2,65	3,06
40	75	3,00	3,43
USAR OS ENCAIXES PARA "U" 40 X 75			
30	68	2,00	1,92
30	68	2,25	2,14
30	68	2,65	2,49
30	68	3,00	2,78
USAR OS ENCAIXES PARA "U" 30 X 68 CH-2,00MM E 2,25MM PERFIS DOBRADERIA.			
22	63	2,00	1,58
27	63	2,00	1,74
U DE FORA			
40	100	2,00	2,75
40	100	2,25	3,08
40	100	2,65	3,59
40	100	3,00	4,03
50	100	2,00	3,07
50	100	2,25	3,44
50	100	2,65	4,02
50	100	3,00	4,51
USAR OS ENCAIXES PARA "U" 40 X 100 E 50 X 100			
32	94	2,00	2,40
32	94	2,65	2,68
32	94	3,00	3,12
32	94	2,65	3,50

A	B	CH	kg/m
U DE FORA			
50	126	2,00	3,49
50	126	2,25	3,91
50	126	2,65	4,57
50	126	3,00	5,14
USAR OS ENCAIXES PARA "U" 50 X 126			
45	118	2,00	3,20
45	118	2,25	3,58
45	118	2,65	4,18
45	118	3,00	4,70
U DE FORA			
50	150	2,00	3,87
50	150	2,25	4,34
50	150	2,65	5,08
50	150	3,00	5,71
USAR OS ENCAIXES PARA "U" 50 X 150			
40	143	2,00	3,44
40	143	2,25	3,85
40	143	2,65	4,50
40	143	3,00	5,06
U DE FORA			
50	200	2,00	4,67
50	200	2,25	5,24
50	200	2,65	6,14
50	200	3,00	6,91
ENCAIXE SOB CONSULTA DE MEDIDAS - CONSULTE-NOS			

### DICA

Os perfis U Tévere permitem diferentes combinações para atender à requisitos do seu projeto. **Consulte-nos!**



# Perfil Estrutural Dobradeira

T9 - Perfil U com 6m

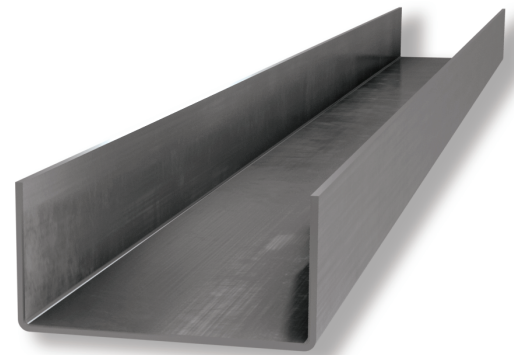
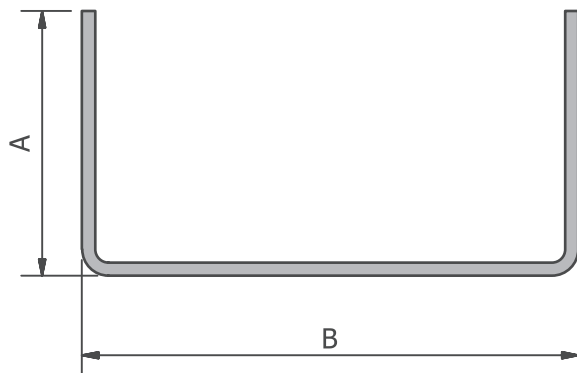

A	B	CH	kg/m
ENCAIXE DO U 25X50			
* 21	45	2,00	1,26
* 21	45	2,25	1,40
ENCAIXE DO U 30X68			
** 22	63	2,00	1,58
** 27	63	2,00	1,74
40	76	4,75	5,21
40	76	6,30	6,59
40	100	4,75	6,12
40	100	6,30	7,80
50	100	4,75	6,88
50	100	6,30	8,81

A	B	CH	kg/m
U DE FORA			
*** 50	126	3,35	5,70
*** 51	128	4,25	7,24
*** 51	129	4,75	8,06
U DE FORA			
**** 51	151	3,35	6,42
**** 51	152	3,75	7,17
**** 51	153	4,25	8,09
**** 52	154	4,75	9,08
50	120	4,75	7,64
52	120	6,30	10,02

Atenção: os asteriscos denominam a regra abaixo:

\*Encaixe do U 25x50

\*\*Encaixe do U 30x68

\*\*\*Usar os encaixes de perfiladeira 45x118

\*\*\*\*Usar os encaixes de perfiladeira 40x143



## DICA

Os perfis de encaixe dobradeira possuem a qualidade para atender todas as suas necessidades. Produzimos perfis terças em dobradeira sob medida.

**Consulte-nos!**

# Perfil "L" cantoneira dobrada

T14 - Cantoneira dobrada

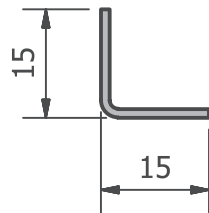

esc. 1:1

CH	COMP.	PESO kg
1,20mm	3000mm	0,80

T15 - Cantoneira dobrada

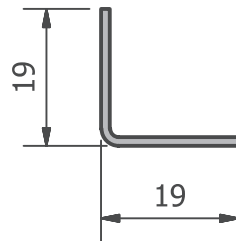

esc. 1:1

CH	COMP.	PESO kg
1,20mm	3000mm	1,02

T16 - Cantoneira dobrada

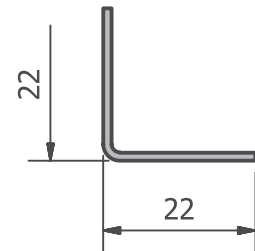

esc. 1:1

CH	COMP.	PESO kg
1,50mm	3000mm	1,50

T17 - Cantoneira dobrada

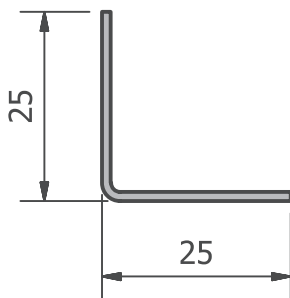

esc. 1:1

CH	COMP.	PESO kg
1,20mm	3000mm	1,40

T18 - Cantoneira dobrada

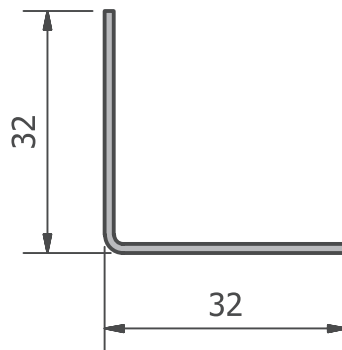

esc. 1:1

CH	COMP.	PESO kg
1,20mm	3000mm	1,76
1,50mm	3000mm	2,16
2,00mm	3000mm	2,84

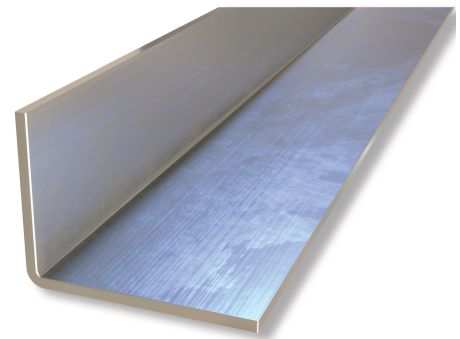

T21 - Cantoneira dobrada

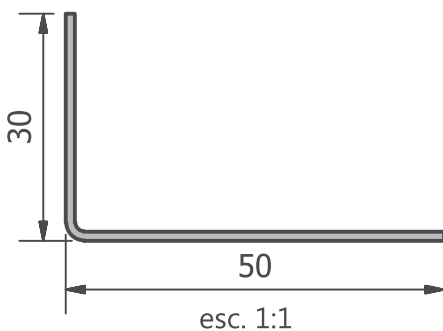

esc. 1:1

CH	COMP.	PESO kg
1,20mm	3000mm	2,28



## DICA

As cantoneiras de chapas dobradas podem ser utilizadas em:

- Janelas
- Portas
- Cantos de paredes

Consulte nossos materiais com medidas em outras espessuras.

# Perfil "U" serralheiro

## T79 - Perfil U serralheiro

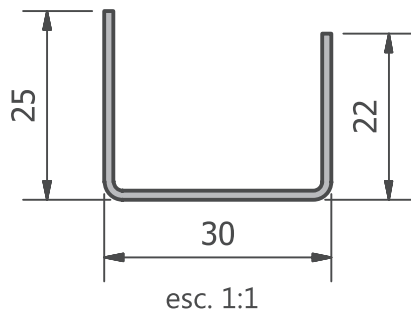

CH	COMP.	PESO kg
1,20mm	3000mm	2,10

## T80 - Perfil U serralheiro

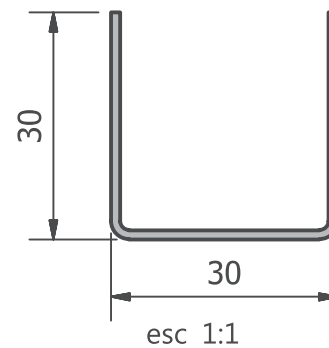

CH	COMP.	PESO kg
1,20mm	3000mm	2,49

## T81 - Perfil U serralheiro

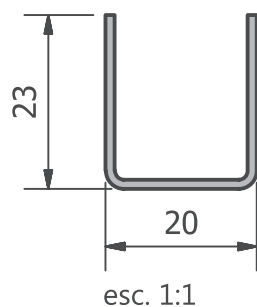

CH	COMP.	PESO kg
1,50mm	3000mm	2,18



## T82 - Perfil U serralheiro

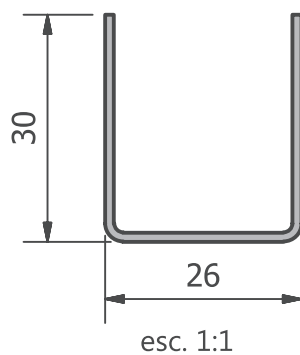

CH	COMP.	PESO kg
1,50mm	3000mm	2,92

### DICA

- O perfil U serralheiro pode ser utilizado em:
- Grades
  - Janelas
  - Portas
  - Acabamentos diversos



# Perfil "U" serralheiro

T83 - Perfil U serralheiro

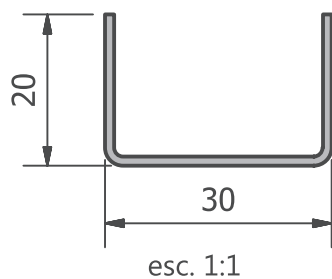

CH	COMP.	PESO kg
1,20mm	3000mm	1,90



T152 - Perfil U serralheiro

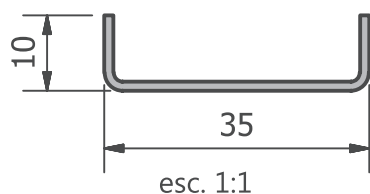

CH	COMP.	PESO kg
1,20mm	3000mm	1,41



## DICA

O perfil U serralheiro pode ser utilizado em:

- Grades
- Janelas
- Portas
- Acabamentos diversos

T179 - Perfil U serralheiro

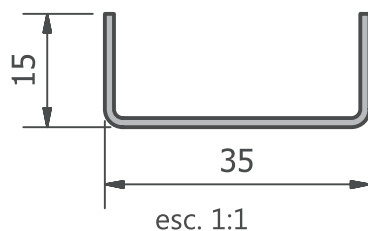

CH	COMP.	PESO kg
1,20mm	2500mm	1,50
1,20mm	3000mm	1,75
1,50mm	3000mm	2,10

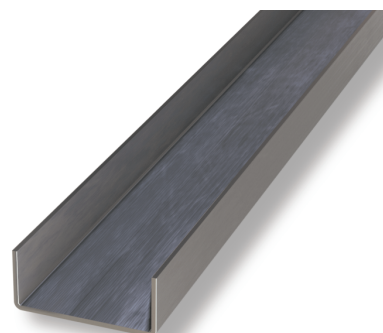

# Perfil para porta de rolo

T6 - Perfil U

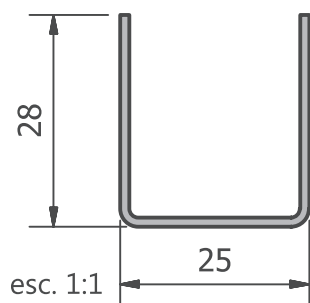

CH	COMP.	PESO kg
1,50mm	3000mm	2,75

T7 - Perfil U

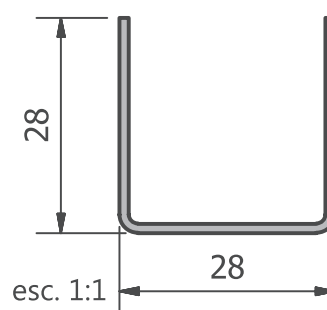

CH	COMP.	PESO kg
1,20mm	3000mm	2,30
1,50mm	3000mm	2,85

T22 - Perfil L

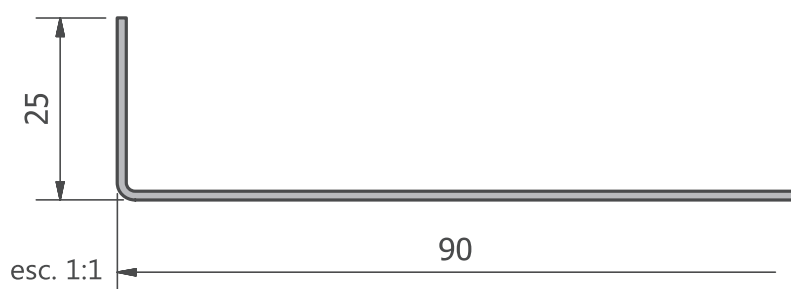

CH	COMP.	PESO kg
1,20mm	3000mm	3,50
1,50mm	3000mm	4,10

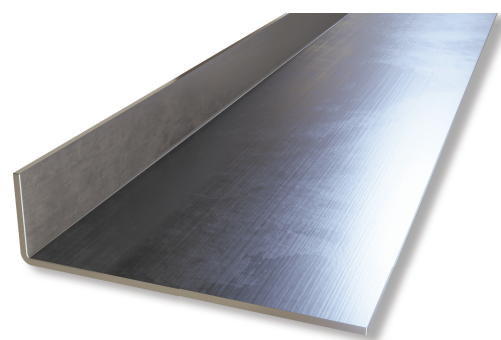

T27 - Perfil H móvel

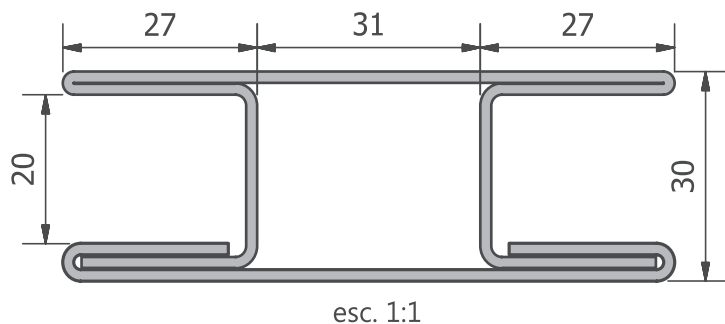

CH	COMP.	PESO kg
1,55mm	3000mm	13,30



## DICA

Utilize o perfil H móvel para obter maior espaço em sua obra / porta / abertura.



# Perfil para pantográfica

T3 - Perfil U

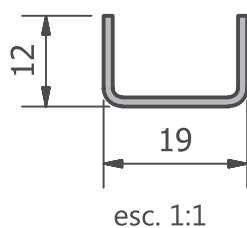

CH	COMP	PESO kg
1,20mm	2300mm	0,85
1,20mm	2500mm	0,92
1,20mm	3000mm	1,10
1,50mm	2300mm	1,00
1,50mm	2500mm	1,09
1,50mm	3000mm	1,30

T76 - Perfil U

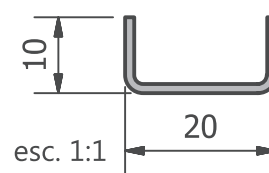

CH	COMP.	PESO kg
1,20mm	2300mm	0,79
1,20mm	3000mm	1,02
1,50mm	2300mm	0,96
1,50mm	2500mm	1,04

T26 - Trilho inferior

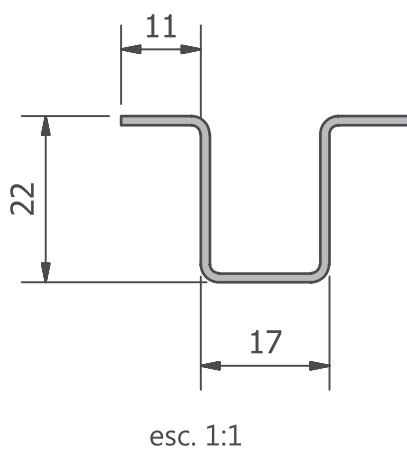

CH	COMP.	PESO kg
1,20mm	3000mm	2,19
1,50mm	3000mm	2,67
1,25mm GV	3000mm	2,28
1,55mm GV	3000mm	2,67

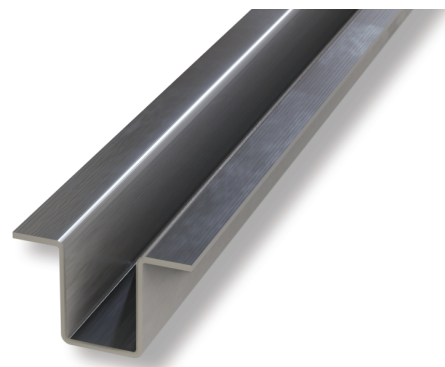

## DICA

Utilize os acessórios Tévere para fabricação de pantográfica, como:

- Arruela
- Haste
- U sanfona
- Puxador U alça
- Bucha
- Guia T maior
- Guia T menor

# Perfil para pantográfica

## T23 - Trilho superior

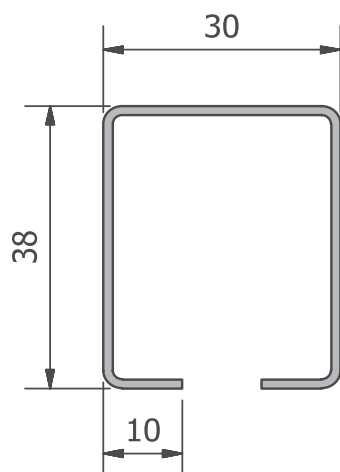

esc. 1:1

CH	COMP.	PESO kg
1,20mm	3000mm	3,40
1,50mm	3000mm	4,17

## T24 - Trilho superior

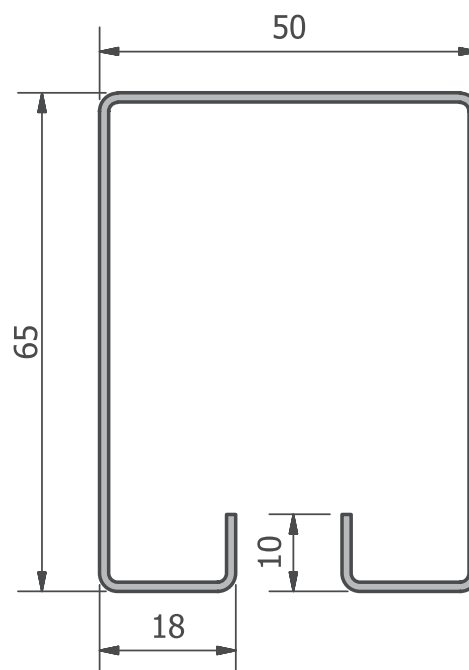

esc. 1:1

CH	COMP.	PESO kg
1,50mm	3000mm	7,98

## T25 - Trilho superior

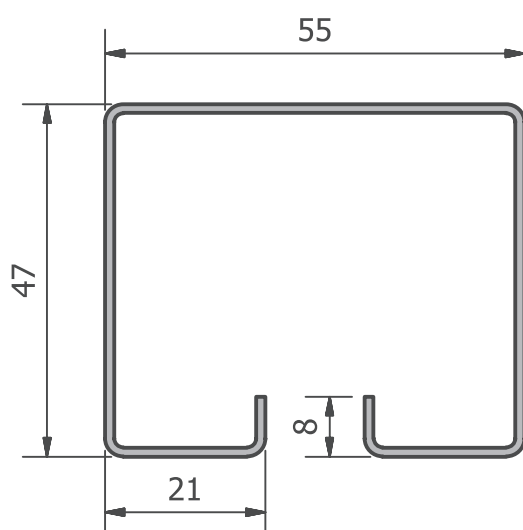

esc. 1:1

CH	COMP.	PESO kg
1,20mm	3000mm	5,65
1,50mm	3000mm	6,99
2,00mm	3000mm	9,10
1,25mm GV	3000mm	5,70
1,55mm GV	3000mm	7,00
2,05mm GV	3000mm	9,37

### DICA

Pode ser utilizado com os rodízios duplos. Ver página 92 no catálogo de acessórios.

